

### GEARBOX INSTALLATION

Satisfactory performance depends on proper installation, lubrication and maintenance. Therefore it is important that the instructions in the Installation and Maintenance leaflet, supplied with each gearbox, are followed carefully. Some of the important aspects of belt and torque-arm installation are listed below.

1. Install pulley on gearbox input shaft as close to the reducer as possible. See fig. 1. Failure to do this will cause excess loads in the input shaft bearings and could cause their premature failure.
2. Install motor and wedge belt drive with the belt pull at approximately  $90^\circ$  to the centre line between driven and input shafts. See fig. 2. This will permit tensioning of the wedge belt drive with the torque-arm which should preferably be in tension. If output hub runs anti-clockwise the torque arm should be positioned to the right. See fig. 3.
3. Install torque-arm fulcrum on a rigid support so that the torque-arm will be at approximately right angles to the centre line through the driven shaft and the torque arm case bolt. See fig. 4. Make sure there is sufficient take up in the turn-buckle for belt tension adjustment.

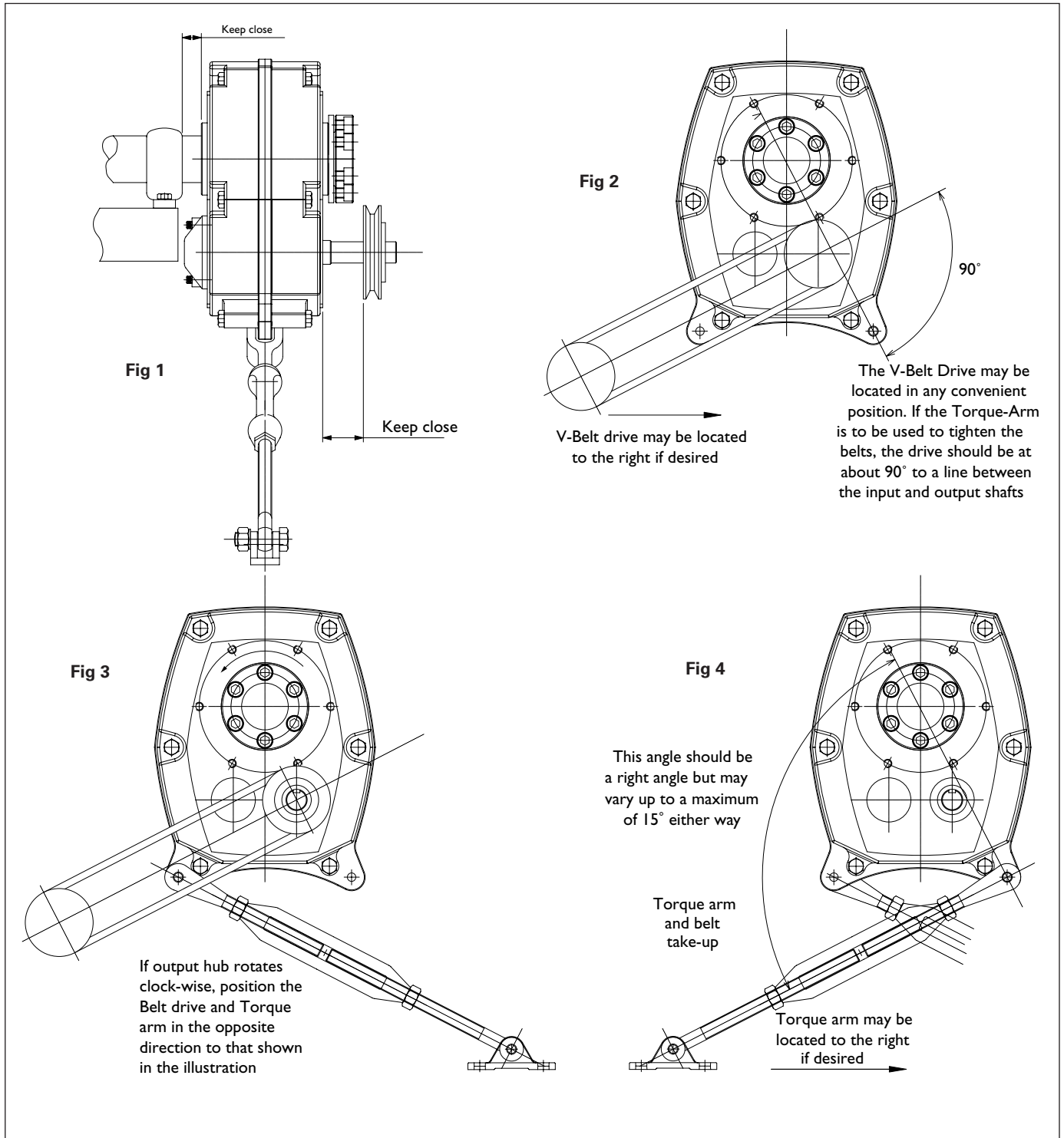

FOR INSTALLATION AND OPERATION OF BELT DRIVES SEE PAGE 74 OF THIS CATALOGUE



FIG. 1 MOUNTING POSITIONS

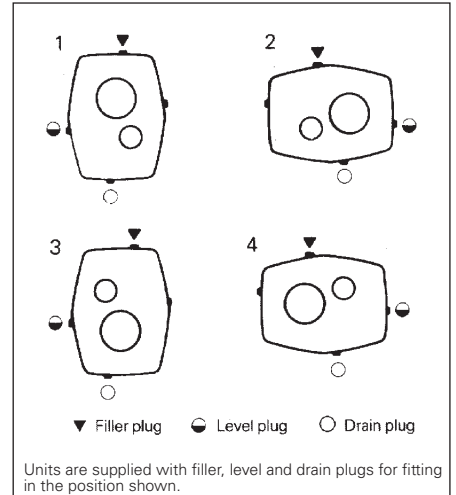

**LUBRICATION – QUANTITIES & RECOMMENDED GRADES**

Fenner Power Plus Shaft Mounted Speed Reducers are dispatched without oil. Before running they should be filled with an appropriate amount of lubricant as shown in the tables, dependent on the mounting position. Fill to level plug when reducer is not running. Drain, flush and refill as directed in the installation leaflet supplied with every gearbox, check oil level regularly.

Positions of filler, breather and drain plug for different mounting positions are shown in fig. 1. **CAUTION.** Too much oil will cause over-heating. Too little oil will cause gear and bearing failure.

Normal operating positions are shown in fig 1. Note that the reducer is supplied with four plugs. After the reducer has been mounted in its running position the plugs must be located as shown in fig 1 for the appropriate mounting position.

If the reducer is not within 20 degrees of one of the positions shown, the oil level plug cannot be safely used to check the oil level. This can be overcome by disconnecting the torque-arm and swinging the reducer around to one of the positions shown. Because of the many positions of fitting the reducer it may be necessary or desirable to make special adaptations using the plug holes in the reducer with standard pipe fittings standpipes or oil level gauges, consult your local Authorised Distributor.

**OIL QUANTITIES (LITRES)**

Unit Size	Approximate Capacity - Litres							
	5:1				13:1, 20:1 and 25:1			
	1	2	3	4	1	2	3	4
B	0.3	0.3	0.3	0.4	0.25	0.4	0.3	0.4
C	0.5	0.5	0.5	0.6	0.4	0.6	0.5	0.6
D	0.8	0.9	0.8	1.0	0.7	0.9	0.8	0.9
E	1.2	1.7	1.4	1.8	1.0	1.8	1.4	1.6
F	2.5	2.6	2.4	2.5	2.3	2.6	2.4	2.2
G	3.3	3.2	3.2	3.3	3.0	3.2	3.2	3.2
H	4.1	5.3	4.1	5.8	3.8	5.5	4.2	5.1
J	5.7	8.6	5.9	8.6	5.4	8.5	5.9	8.3
S	10.9	18.4	13.6	18.4	9.1	16.4	12.6	15.4
T	15.2	21.7	25.2	20.7	12.7	21.7	15.7	19.2
K					12.5	13.5	24.0	11.5
L					22.5	34.0	52.0	27.0
M					36.0	50.0	79.0	45.0

**MINERAL OIL**

	Ambient Temp °C	5:1 RATIO GEARBOX				13:1 AND 35:1 RATIO GEARBOXES							
		0-100 rev/min		101-200 rev/min		0-20 rev/min		21-50 rev/min		51-120 rev/min		0 to 50 rev/min	51 to 80 rev/min
		BCDEFGHJST	BCDEFGHJST	BCD	EFGHJST	BCDEFGHJST	BCDE	FGHJST	BCDE	FGHJST	KLM		
<b>I.S.O.</b>	-10 to +5	100	100	100	68	150	150	150	100	100	100	100	
<b>Viscosity Grade</b>	6 to 25	460	320	320	220	680	680	460	460	320	320	220	
	26 to 40	800	680	680	460	800	800	800	680	460	460	320	

**MANUFACTURERS AND TYPES**

B.P. ENERGOL GR-XP	CASTROL ALPHA ZN OR SP	MOBIL MOBILGEAR & SHC	SHELL OMALA	TEXACO MEROA
--------------------------	------------------------------	-----------------------------	----------------	-----------------

NOTE: Do not use E.P. mineral oils other than those recommended when using a backstop.