

Content Installation and Operation Manual

1. Introduction
2. Storing and transportation
3. Installation and preparation
4. Dismounting of an existent valve
5. Mounting in the piping system
6. Cleaning of the piping system
7. Function control
8. Application

1. Introduction

For achieving a proper functionality it is compulsory to follow this Installation and Operating Manual. Only qualified personnel are allowed to install the valve. Qualified personnel is called personnel who is familiar with installation, fitting, initiation, operating and maintenance of the device. The manufacturer and distributor will not assume liability for faults resulting of improper installation. Detailed information about the valve (dimensions, materials and operating conditions) can be seen in the Butterfly Valve Series 49, Product Information.

2. Storing and transportation

The ECON Butterfly Valve Series 49 delivered is ready-for-use. It has to be treated with the appropriate care and it has to be transported and stored in the original packing. Never expose the unprotected ECON Butterfly Valve Series 49 to dust or humidity. While shipped, the valve is in a slight opened position. This status has to be kept until the valve has been mounted.

3. Installation and preparation

3.1 Intended application

The application area of the ECON Butterfly Valve Series 49 is subject to the responsibility of the operator of the facility. It is only allowed to use the ECON Butterfly Valve Series 49 within the range of pressure and temperature which shows the documentation „Product Information“. The resistance of corrosion and media of the valve, the pressure and the temperature have to be verified for particular operating conditions!

3.2 Flange and Piping Connection

The inner diameter of the pipe has to feature at least the corresponding Y value of the following table. In this case the disc has enough play concerning the internal surface of the pipe. The ECON Butterfly Valve Series 49 as a wafer and lug valve has been designed exclusively for installation together with weld neck flanges according to DIN EN 1092-1, Type 11, PN 10-16 and to ASME ANSI B16.5/B16.47 Class 150

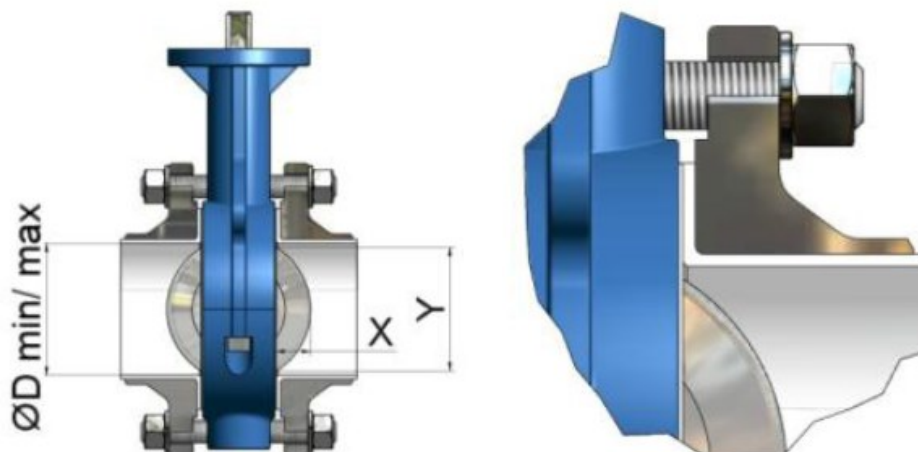

Inch	X	Y	Dmin	Dmax	DN
1½"	7	34	37*	43.1	40
2"	6	31	34*	54.5	50
2½"	11	48	51*	70.3	65
3"	17	63	66*	82.5	80
4"	27	90	93*	107.1	100
5"	38	118	121*	131.7	125
6"	47	137	140*	159.3	150
8"	71	189	192*	206.5	200
10"	92	239	242*	260.4	250

Inch	X	Y	Dmin	Dmax	DN
12"	112	290	293*	309.7	300
14"	125	328	331*	341.4	350
16"	146	377	381*	392.2	400
18"	164	417	421*	442.8	450
20"	184	477	481*	493.8	500
24"	215	560	564*	595.8	600
30"	289	716	721*	736.6	
36"	360	861	865*	894.0	900
42"	433	1009	1014*	1022.4	

3.3 Positioning / Fitting Position

If the ECON Butterfly Valve Series 49 will be mounted in a horizontal piping system we recommend to install the shaft of the valve also in a horizontal manner. The lower edge should open in the direction of the flow. This method avoids the deposition of pollution in the area of the shaft seal.

3.4 Flange Sealing

The ECON Butterfly Valve Series 49 with its TFM - Liner needs no sealing if it has been mounted between plane flanges. In case of installation together with non plane flanges (e.g. gummed or enamelled coils of flanges) the use of a PTFE coated sealing is recommended.

4. Dismounting of an existent valve

4.1. Warning and Precaution

- During installation and maintenance work adequate protective clothing, work gloves and protective goggles have to be worn.
- For installation and maintenance the pipe has to be depressurized and depleted. If the valve should be applied with dangerous flow mediums, the pipe has to be depleted completely and rinsed with an adequate cleaning fluid. Inappropriate mediums can harm the valve!

4.2. Procedure

1. Turn the disk in a slight opened position.
2. Release and remove all flange connections of the valve.
3. With the adequate tool force the flanges apart and lift the disc out of the piping system.

4.3. Disposal

Inside the valve it is possible that residues exist which are harmful to human and environment. Therefore the valve has to be treated with the adequate precaution. Parts of the valves which are no longer serviceable have to be disposed professional and beneficial to the environment.

5. Mounting in the piping system

5.1. Basics

It is absolutely forbidden to mount the ECON Butterfly Valve Series 49 between flanges which are not positioned parallel to each other. The axis of the pipes and valves have to be aligned. Furthermore it is prohibited to weld on the pipe while the ECON Butterfly Valve Series 49 is mounted between the flanges. This would destroy the liner of the ECON Butterfly Valve Series 49. If a lug styled butterfly valve will be installed at the end of the pipe it is mandatory to mount additionally a blind flange as the closing element!

5.2. Recommended Locked Torques of the Flange Screws

The PTFE or TFM material of the liner tends to cold flow. Therefore the following locked torques have to be applied:

Table about Locked Torques

Inches	1½"	2"	2½"	3"	4"	5"	6"	8"	10"	12"	4"	16"	18"	20"	24"	30"	36"	42"
DN	40	50	65	80	100	125	150	200	250	300	350	400	450	500	600		900	
Locked Torque (NM)	25	35	40	45	50	60	70	85	95	105	145	165	185	215	230	300	460	500

5.3 Procedure

1. Clean connection flange and sealing surface in order that the lining of the valve as well as the plane flanges will not be destroyed.
2. Remove the casing of the valve.
3. Shift the valve with its slight opened position of the disk (the edge of the disk has to be placed behind the edge of the liner!) accurately between both flanges.
4. Center the valve with screws and studs respectively.
5. Tighten the screw-nut by hand. Subsequently adjust the valve, flange pipe and sealing.
6. Open the valve slowly and fully.
7. Tighten the greased screws and screw-nuts diagonally with the recommended lock torques shown in chapter „5.2. Recommended Locked Torques of the Flange Screws“.

5.4. Conform Version to ATEX in the Cluster II

In explosive areas the earth connection adapter of the ECON Butterfly Valve Series 49 ATEX Version has to be connected with the correspondent earth connection adapter to establish the appropriate join.

6. Cleaning of the Piping System

After the installation the ECON Butterfly Valve Series 49 has to be opened fully and the piping system has to be rinsed before closing the valve. Cleaning mediums and purifiers have to be compatible with the valve. Improper medium and purifiers can damage the valve.

7. Function Control

Subsequent to the cleaning the ECON Butterfly Valve Series 49 has to be activated several times checking its free moving space.

8. Application

The ECON butterfly valves are used for industrial systems gasses and liquids. The valves are designed for standard operating conditions. For the use of extreme conditions e.g. aggressive or abrasive media, it is recommended to mention this at the ordering stage, to verify whether the valve is suitable. The installation designer is responsible for the valve selection, suitable for the working conditions. The valves are unsuitable, without written permission of the manufacturer, to apply for hazardous media as referred into Regulation (EC) No 1272/2008.

Content Maintenance Instruction

- 9. Introduction
- 10. Parts list
- 11. Dismounting
- 12. Disassembling
- 13. Assembly
- 14. Storage and transportation
- 15. Installation in the piping system
- 16. Application

9 Introduction

Only qualified personnel are allowed to do maintenance work on an ECON Butterfly Valve Series 49. Only original spare parts may be used. For faults due to repair work the manufacturer or distributor will not assume liability. The fluoropolymer (PTFE) parts of the ECON Butterfly Valve Series 49 are very delicate. An injury of these parts will easily lead to a leakage. Considering this, the parts have to be handled very carefully. This instruction refers to the exchange of the liner and the disc. Detailed information concerning the device (dimensions, materials and range of applications) can be found in the document „ECON Butterfly Valve Series 49 - Product Information“.

10 Parts list

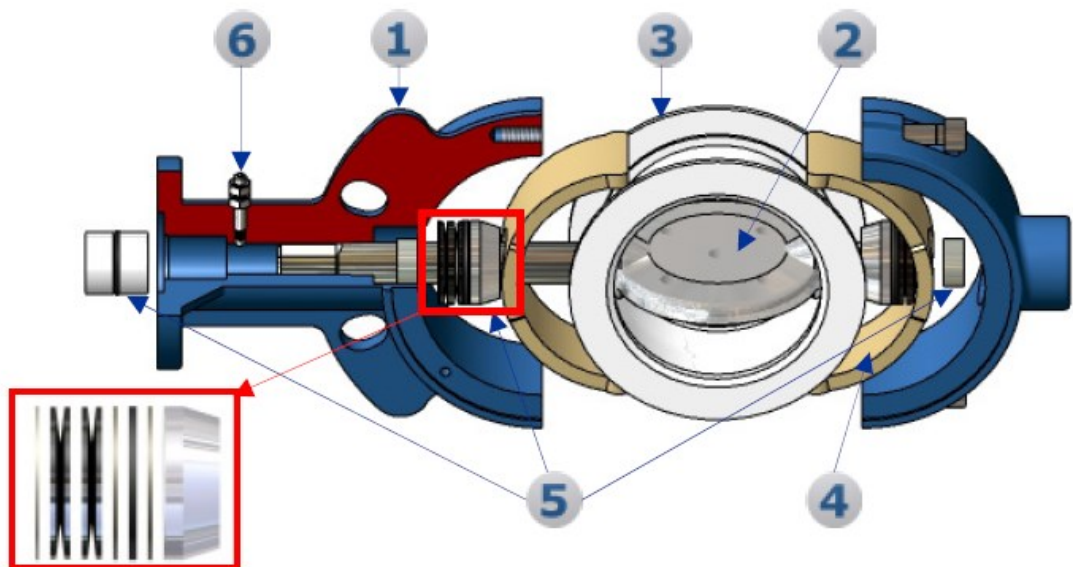

Position	Description	Bezeichnung	Position
1	Split Body	2-teiliges Gehäuse	1
2	Disc	Klappenscheibe	2
3	Liner	Ringbalg	3
4	Back-Up	Einlage	4
5	Complete Bearing and Pressure Package	Komplettes Lager- und Druckpaket	5
6	Atex Type*	Atex Ausführung*	6

11 Dismounting

11.1 Warning and precaution

During installation and maintenance work adequate protective clothing, work gloves and protective goggles have to be worn.

- For installation and maintenance the pipe has to be depressurized and depleted. If the valve should be applied with dangerous flow mediums, the pipe has to be depleted completely and rinsed with an adequate cleaning fluid. Inappropriate mediums can harm the valve!
- If flange connections or locking screws will be detached, hot water, steam, caustic fluids or toxic gases can emit. Heavy scalds and burn-ups on the whole body as well as grave contamination are possible!
- During operation the valve is hot or very cold. Installation and maintenance work have only to be realized, if the valve's temperature is the same as the ambient temperature.
- Previous to the dismounting of the valve preventive measures and dispositions against the possible leakage of dangerous mediums have to be made.
- While dismounting the valve pay attention that disc and liner will not be injured. It is mandatory to replace broken parts with original replacement parts.

11.2 Procedure

1. Turn the disk in a slight opened position.
2. Release and remove all flange connections of the valve.
3. With the adequate tool force the flanges apart and lift the disc out of the piping system.

11.3 Disposal

Inside the valve it is possible that residues exist which are harmful to human and environment. Therefore the valve has to be treated with the adequate precaution. Parts of the valves which are no longer serviceable have to be disposed professional and beneficial to the environment.

12 Disassembling

12.1 Precautions

Hand lever, gear or actuator has to be dismantled. Prior to disassembling both body halves have to be marked so that after maintenance work the body will be assembled accurate to side.

12.2 Separating of the split body

Loosen both screws on the body and alternately unscrew in several steps. Pull upper half of body off. Pull liner and disc off lower body half whereas the correct order of the spring set has to be noted for the assembling later. Remove the silicone back up.

12.3. Dismantling of the disc out of the liner

To disassemble the PTFE or TFM material of the liner easier, it has to be put in the oven with the disc for at least 5 minutes at 180° C. Take liner out of the oven and open disc 90° to liner. Trough the warming up treatment the liner can be squeezed in oval shape. This way the short end of the disc can be extended. Damaged liners can be cut in pieces and disposed professional.

13 Assembly

13.1 Precautions

Prior to the assembling, all parts have to be cleaned thoroughly and checked properly for damages and scratches. Damaged parts have to be replaced only with original parts. Use only new gaskets.

13.2 Assembling of the disc in liner

In preparation the liner has to be warmed up at least 5 minutes at 180° C and the shaft has to be fixed in a vice using protecting jaws. When the liner is warmed up sufficient push the long end of the spindle through the liner. As the disc is in 90° position to the liner, the liner has to be squeezed oval and the short end of the shaft has to be pushed in. Now the disc has to be turned in closed position. Trough to squeezing manually in warm condition the liner can still be formed into the initial shape.

13.3 Assembling of liner in body

The further assembling has to be with the still warmed up liner. The spring set has to be put into the lower body half in correct order. After this insert the silicone back up. The stub shaft with the liner has to be put into the lower body half. After that the upper silicone back up can be placed and the upper spring set mounted in the switch shaft. Both back-ups have to be controlled permanently of correct positioning.

13.4 Screwing of body halves

During the true sided assembling of both body halves (The marking done when preparing the disassembling helps) the valve has to be turned repeatedly trough to the liner. The body socket screws have to be tightened while the valve is in closed position.

After assembling effective the revised ECON Butterfly Valve Series 49 has to be checked (tested) regarding functionality and tightness.

14 Storage and transportation

After the effective final check, the disc of the ECON Butterfly Valve Series 49 has to be in a slight opened position. For the transport use the original packing material. Never expose the unprotected ECON Butterfly Valve Series 49 to dust or humidity. If the original packing material is not available anymore, equal packing material in so far as functionality has to be created.

15 Installation in the piping system

Please find these details in the text above „ECON Butterfly Valve Series 49 – “Installation and Operating Manual“.

16 Application

The ECON butterfly valves are used for industrial systems gasses and liquids. The valves are designed for standard operating conditions. For the use of extreme conditions e.g. aggressive or abrasive media, it is recommended to mention this at the ordering stage, to verify whether the valve is suitable. The installation designer is responsible for the valve selection, suitable for the working conditions. The valves are unsuitable, without written permission of the manufacturer or distributor, to apply for hazardous media as referred into Directive 67/548/EEC.