

ECON Limit Switch Box Fig. 79652



Scan for manual

Installation & Operation Manual for Limit Switch Box: Fig. 79652

Contents	Page
1. INTRODUCTION	3
2. SWITCH BOX SPECIFICATION	3
3. SWITCH TYPE SELECTION	3
4. SWITCH BOX MARKING	3
5. STANDARD FEATURES	4
6. INITIAL INSPECTION	5
7. STORAGE	5
8. INSTALLATION	5
8.1 Mounting of the Limit Switch Box	5
8.2 Setting of switch/sensor cams	6
8.3 Cam types	6
8.4 Wiring of the Limit Switch Box	6
8.4.1 Mechanical switch - 2 SPDT (Standard)	7
8.4.2 Mechanical switch - 4 SPDT	7
8.4.3 Proximity switch - P&F NBB2-V3-Z4L	8
8.4.4 Proximity switch - P&F NBB2-V3-E2	8
8.4.5 Mechanical switch - 2 SPDT with CPT, Current Position Transmitter (Optional)	9
8.5 Setting of the Current Position Transmitter unit – CPT (Optional)	9
8.5.1 Calibration of the potentiometer	10
8.5.2 Calibration of the zero span	10
9. MAINTENANCE	10
10. TROUBLE SHOOTING	11
11. TOOLS	11
12. GENERAL INSTALLATION AND MAINTENANCE TIPS	11

1 INTRODUCTION

The ECON Fig. 79652 limit switch box is designed to provide accurate and reliable valve position information of actuated valves and hand operated valves.

The Fig. 79652 limit switch box consists of an aluminium body a polycarbonate visual position indicator, quick-set cam assemblies, terminal strip, switch assemblies and an easy mounting bracket. Quick-set cams enable rapid manual switch adjustments. Tools are not required.

2 SWITCH BOX SPECIFICATION

Model:	Fig. 79652
Enclosure rating:	Weather-proof IP67, NEMA 4, 4X and 6. (optional IP68, NEMA 6P)
Enclosure:	High grade anodized Aluminium alloy
Ambient temperature range:	-20°C (-4°F) up to +80°C (176°F)
Conduit entries:	2x M20x1,5 or 2x NPT1/2" (optional PG13,5)
Travel angle:	90° +/-10%
Visual position indicator:	Open: Yellow; Close: Red. Language: English (Open / Closed)
Switch types:	See chapter 3 for standard switch types
Terminal strip	8 point; 0,08-2,5mm ² (optional : 9 to 14 points)
External coating:	Dry powder polyester
Potentiometer (optional):	1kΩ (optional : 0~5kΩ , 0~10kΩ)
Current output signal unit (optional):	4~20mA, 20~4mA

3 SWITCH TYPE SELECTION

ECON code	Position feedback devices	Switch/Sensor specification
EC79652000AMS	Micro Switch, 2-SPDT	Starion, SZM-V16-5FA-61
EC79652004AMS	Micro Switch, 4-SPDT	Starion, SZM-V16-5FA-61
EC7965200APS22	Proximity Sensor, 2-wire (minimum off-state current)	Pepperl & Fuchs, NBB2-V3-Z4L
EC79652000APS3	Proximity Sensor, 3-wire	Pepperl & Fuchs, NBB2-V3-E2
EC79652000CPT	4-20mA position transmitter (CPT) and Micro Switch, 2-SPDT	Starion, SZM-V16-5FA-61

Other switches or sensors can be fitted upon request. Please contact your local distributor.

4 SWITCH BOX MARKING

- ECON-logo
- Figure number (Fig.)
- Switch type specification
- Switch certification information
- QR-code for I.O.M (Installation and Operation Manual)
- Enclosure rating

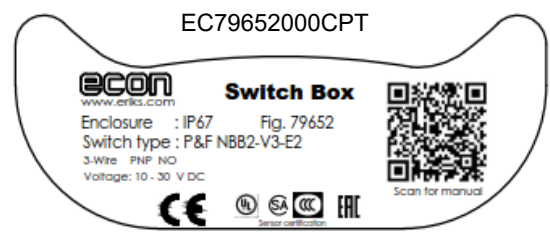
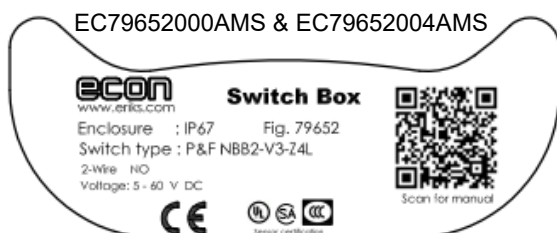

EC79652000AMS & EC79652004AMS

EC79652000CPT

5 STANDARD FEATURES

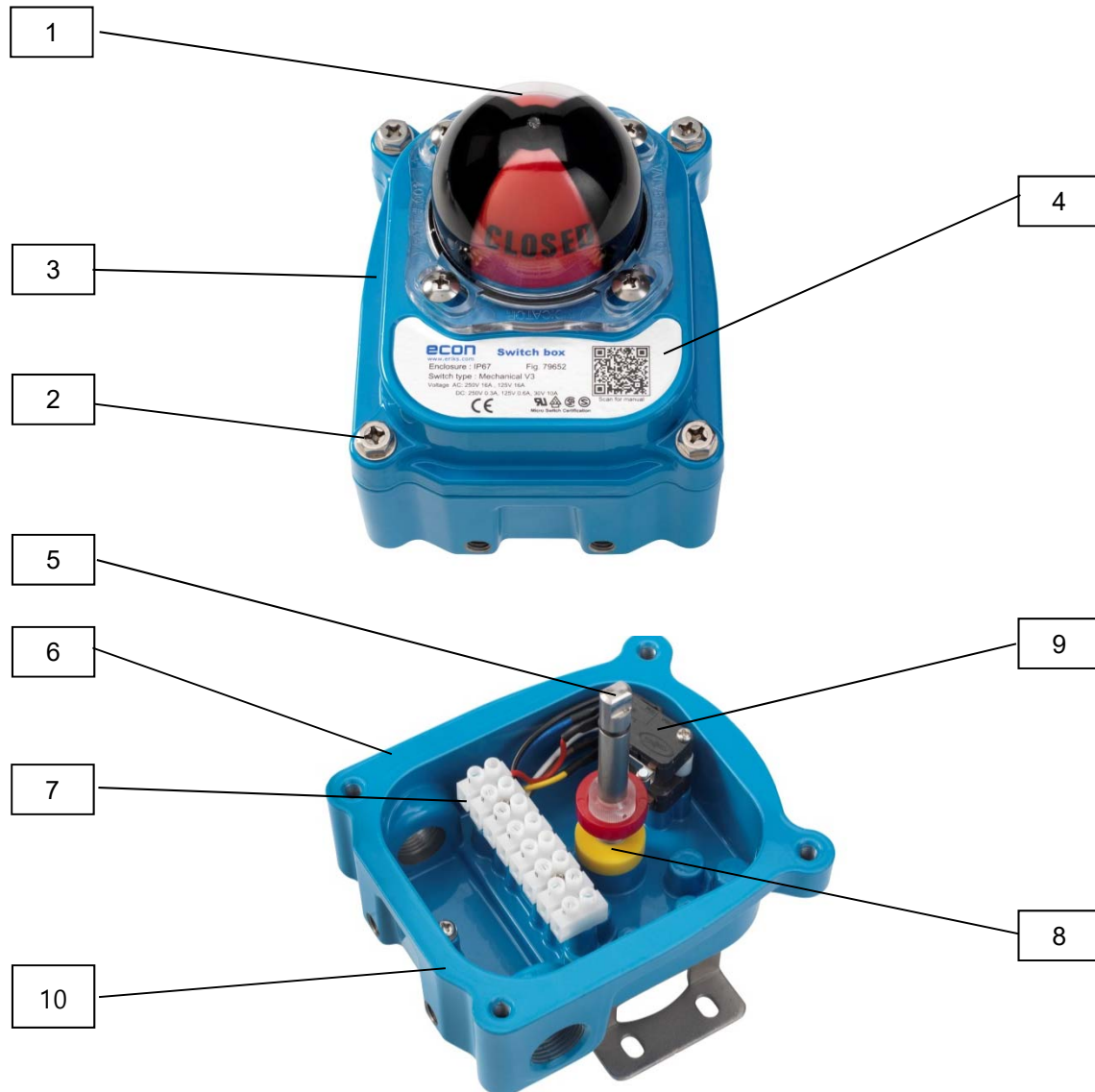

No.	Part Name	Q'ty	Description
1	Window / Indicator	1	Polycarbonate / ABS
2	Cover Captive Cover Bolt	4	Stainless steel
3	Cover	1	Aluminium Die casting
4	Name Plate	1	Sticker
5	Shaft	1	Stainless steel
6	Body	1	Aluminium Die casting
7	Terminal Strip	1	8 positions
8	Cams	2	PC
9	Switch	2	See switch type specification (chapter 3)
10	Grounding Lug	1	Stainless steel

6 INITIAL INSPECTION

Upon on the receipt of the switch box, the user should inspect the condition of the product and ensure that the product specification stated on the name plate matches with the order sheet.

- Remove the packing wrap or cardboard box carefully. Inspect the product for any physical damage that may have occurred during shipment.
- Check the product specification of the received product. If a wrong product has been supplied, please immediately report this to the distributing company.

7 STORAGE

Limit switch boxes must be stored in a clean, cool and dry area. The unit should be stored with the cover installed and the conduit openings sealed. Storage must be off the floor, covered with a sealed dust protector.

8 INSTALLATION

8.1 Mounting of the limit switch box

CAUTION: PREVENT INJURIES

Before installing the limit switch box on the actuator, air supply and power supply of the pilot valve must be shut off.



ECON limit switch boxes are supplied with a mounting bracket according to the VDI/VDE 3845 (NAMUR) standard. This standard bracket is selected for actuators with a VDI/VDE connection 30x80 mm and an actuator shaft height of 30mm. Brackets for other VDI/VDE dimensions are available upon request and are mentioned in the table below.

Available bracket sizes	ECON code
30x80mm, Height: 30 mm (standard)	EC7965X0BR80X30
30x80mm, Height: 20 mm	EC7965X0BR80X20
30x130mm, Height: 30 mm	EC7965X0BR130X30

- Put the actuator in the fully open or closed position.
- Mount the bracket on the switch box.
- Put the switch box with bracket on the actuator and do not tighten the bolts yet (4 pieces).
- Check the actuator shaft and switch box shaft alignment
- Check if the position of the open and closed switches/sensors and also the visual position indicator corresponds with the valve position.
- Tighten the bolts in order to secure the bracket to the actuator (4 pieces).
- Check again if the position of the open and closed switches/sensors and also the visual position indicator corresponds with the valve position.

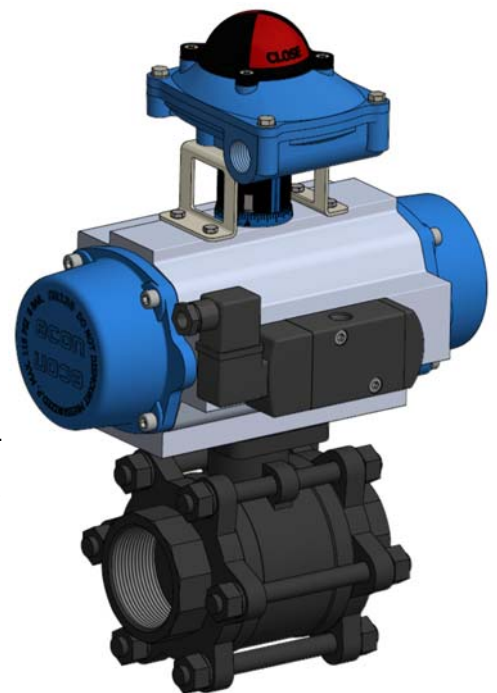

8.2 Setting of switch/sensor cams

The colour of the cams corresponds with the visual position indicator. Cams can be easily set without using any tools. ECON cams have a spline connection and can be set by lifting or pushing down the cams over the shaft. The cams are spring loaded and therefore self-locking.

Note : Cams are pre-set by the factory for most standard applications. This setting however must always be checked before commissioning.

- Loosen the switch box cover bolts.
- Remove the cover carefully.
- Setting of the open-cam setting:
 - Put the actuator in the fully open position.
 - Lift the yellow (lower) cam and rotate it until the switch is activated.
 - Release the cam and it will lock itself to the shaft.

- Close cam setting
 - Put the actuator in the fully closed position.
 - Push the red (upper) cam down and rotate it until the switch is activated.
 - Release the cam and it will lock itself to the shaft.

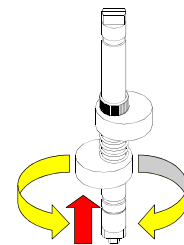
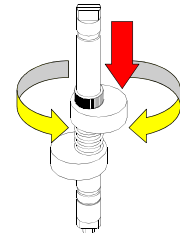

8.3 Cam types

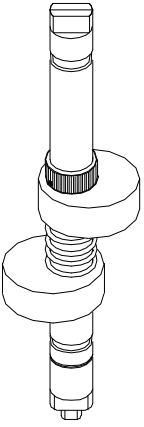
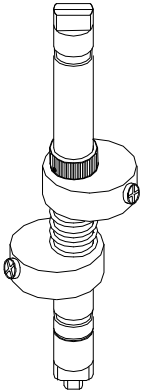
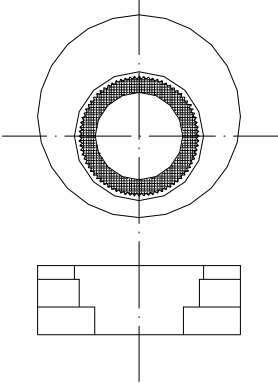
Cams for mechanical switches	Cams with metal insert for proximity sensors	Splined cam
		

8.4 Wiring of the limit switch box

DANGER:

HAZARDOUS VOLTAGE. Electrical power must not be connected until all wiring and limit switch adjustments have been completed. Once the power is supplied to the actuator, precautions must be taken if the cover is not mounted.



ECON limit switch boxes have prewired switches. All user connections must be made on the numbered terminal strip. A wiring diagram, located inside the cover, indicates which terminal numbers correspond with switch contacts. Follow

the wiring diagram in order to make a correct connection to your system.

A solenoid valve may also be wired through the ECON limit switch box. Two auxiliary terminals (EXT) are included as a standard.

ECON limit switch boxes have two cable entries and are being supplied with a blanking cap/plug. A cable gland must be selected by the user or installer and must meet the applicable enclosure rating.

8.4.1 Mechanical switch – 2 SPDT (Standard)

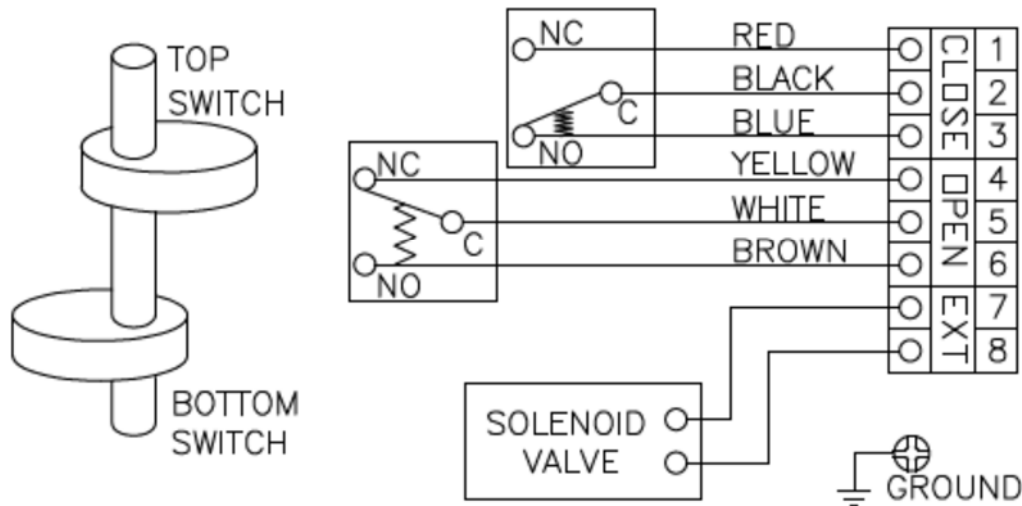

8.4.2 Mechanical switch – 4 SPDT

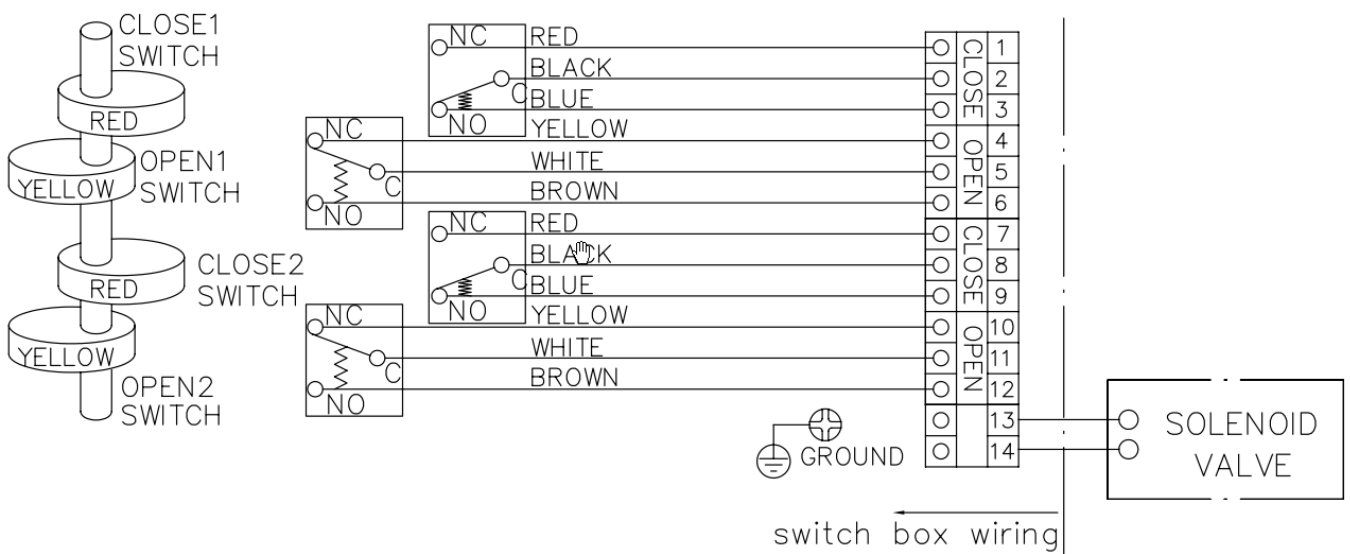

8.4.3 Proximity switch - P&F NBB2-V3-Z4L

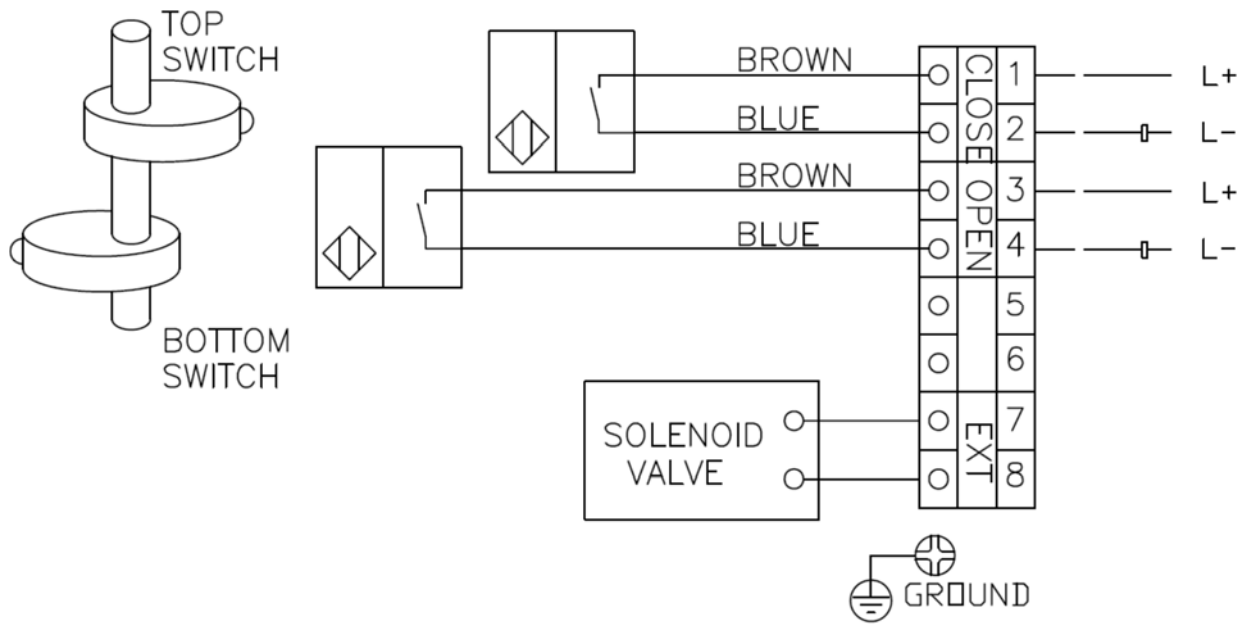

8.4.4 Proximity switch - P&F NBB2-V3-E2

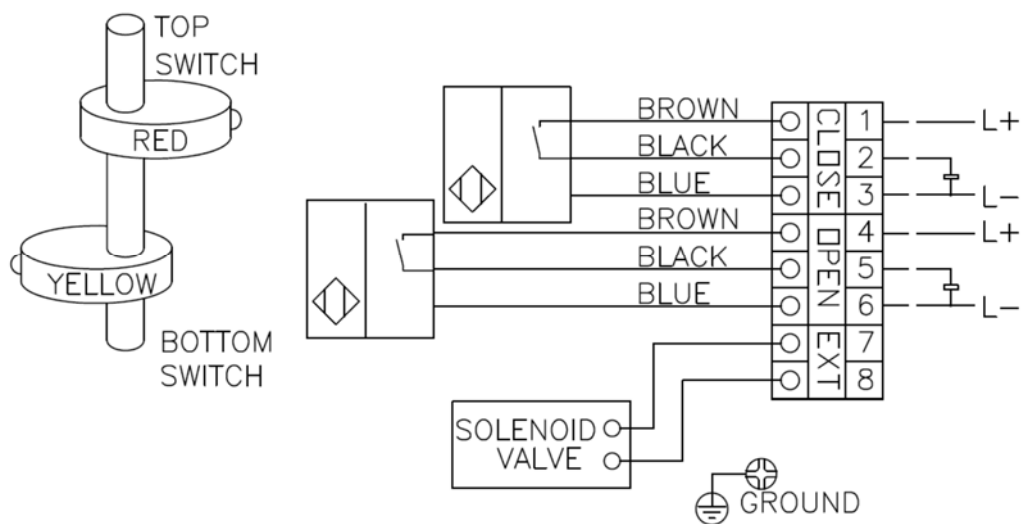

8.4.5 Mechanical switch - 2 SPDT with CPT, Current Position Transmitter (Optional)

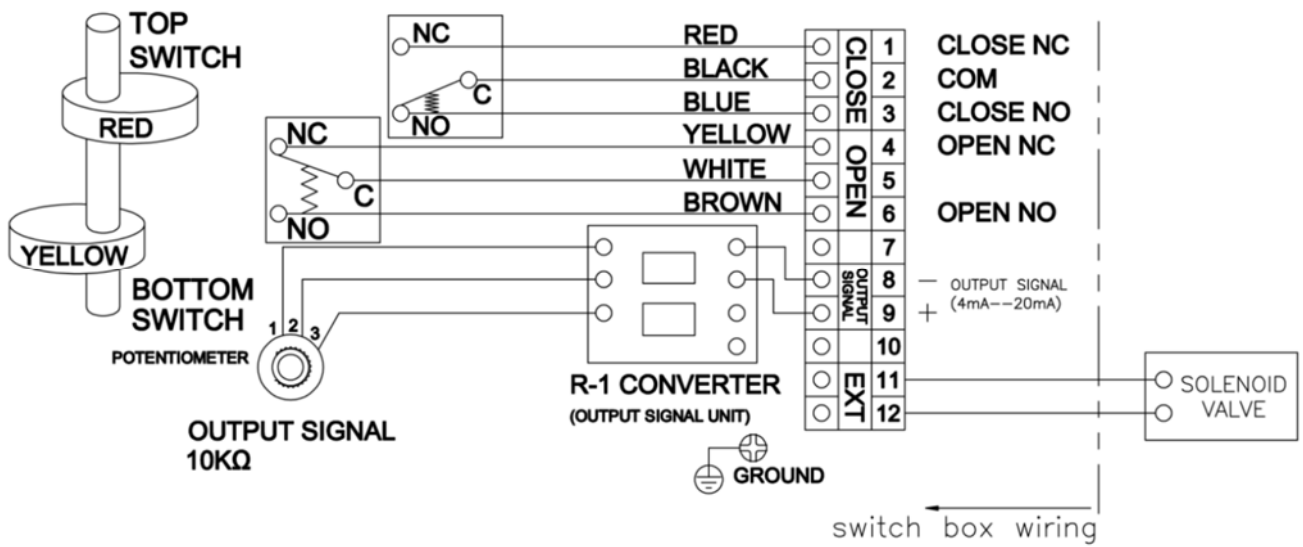

Note:

- *The limit switch box must be grounded at all times.*
- *At least a 2 sq. mm wire is recommended for grounding.*

8.5 Setting of the Current Position Transmitter unit – CPT (Optional)

A potentiometer reads the current position of the actuator (valve) and transmits a resistance value to the position transmitter PCB. The transmitter indicates the actuator (valve) position throughout the complete stroke and converts resistance value it into a 4 to 20mA output signal.

Technical features

Power supply range:	12.5 to 37VDC (25V typical)
Current signal output:	4 to 20mA
Max. load resistance:	Max. resistance (Ohm) = (Supply voltage – 12.5) / 0.02
Potentiometer:	0 to 500Ω / 10kΩ
Operation temperature:	-20 to 60°C (-4°F to 140°F)
Dimension:	40 x 60 x 15mm

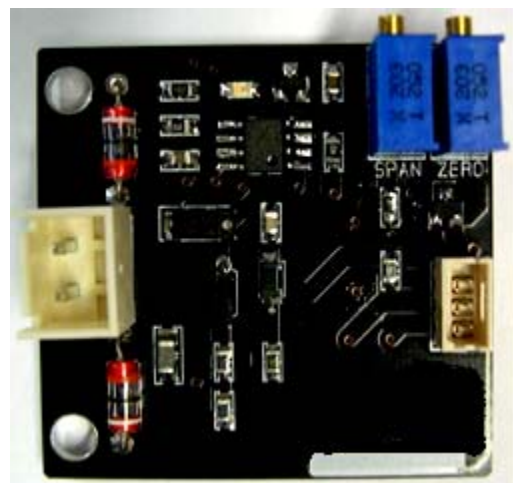
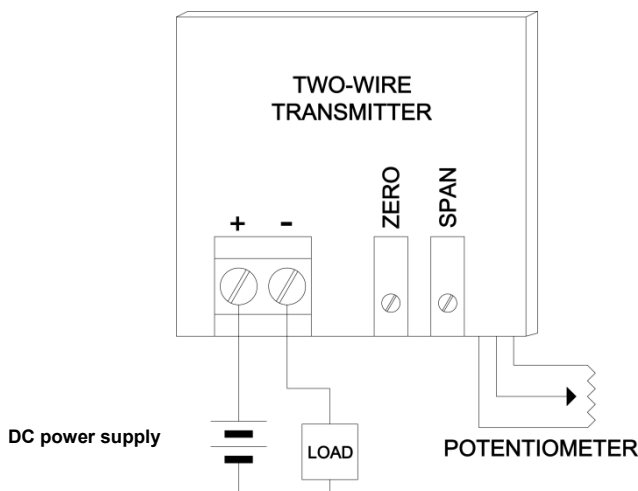

8.5.1 Calibration of the potentiometer

- Operate the actuator into the closed position.
- Connect an Ohm-meter to the P1 and P3 resistor. The value shall be approximately 1kΩ.
- Loosen the potentiometer gear wheel from the shaft and connect the Ohm-meter to P1 and P3 and rotate the gear wheel gently until a value between 80 to 120Ω is achieved (100Ω preferred!). While maintaining the value, tighten and lock the gear wheel to shaft.

8.5.2 Calibration of the zero span

The zero span setting has been calibrated by manufacturer. However, if re-calibration is required, please follow the hereunder mentioned instruction:

- Operate the actuator to the middle position and thereafter to the fully closed position.
- As soon as the actuator reaches the fully closed position, adjust the “zero” rotary switch on the PCB until a value of 20mA is achieved.

9 MAINTENANCE

The ECON Fig. 79652 limit switch box is designed to provide accurate and reliable valve position signalling and indicating of most automated valves.

WARNING:

- ***Inspection and maintenance work must be performed by qualified and trained personnel***
- ***When working in potentially explosive areas, the standard EN 60079-14 “Electrical Installations in Hazardous Areas” must be observed.***
- ***Work on an open limit switch box, which is under voltage, may only be performed if there is no explosion risk.***
- ***Observe local and national regulations and legislation.***
- ***Flame proof enclosures may only be opened if there is no explosion risk.***



CAUTION:

- ***Shut-off all incoming power or air supply on the valve actuator before starting maintenance work on the limit switch box.***
- ***Be sure that the working area is clean before disassembling the limit switch box. Clean all parts and seals before re-assembling.***
- ***Use only genuine spare parts, which can be purchased from your local ECON distributor.***



Maintenance should be performed every six month or after every 100,000 operation cycles. In severe operation conditions inspections must be performed more frequently. During maintenance the following parts of the limit switch box must be inspected:

- Check the alignment of the valve, actuator and limit switch box.
- Check the wiring insulation and the terminal strip connections.
- Check the adjustment of the cams.
- Check the cams on wear and replace them if necessary.
- Check if all screws are present and tightened.
- Check if the cable connections are installed properly and not leaking.
- Check internal devices for condensation.
- Check the enclosure for damages, especially on the sealing surfaces.
- Check the enclosure O-ring seals and also check if the O-ring is in the correct position.
- Visually inspect the limit switch box during operation.
- Inspect the type plate of the limit switch box and replace it if necessary.

10 TROUBLESHOOTING

The following instructions are offered for the most common difficulties that could be encountered during installation and start-up.

Signal errors to main control room.

- Check if the wiring of the limit switches/sensors is in accordance to the wiring diagram.
- Check if the cams or switches/sensors are damaged or broken.
- Check the connections on the terminal strip.
- Re-set the limit switch box
- Check the potentiometer gear for jamming (if present)
- Check the zero and span calibration if a CPT has been installed.
- Check the PCB for damages if a CPT has been installed.

11 TOOLS

For installation or maintenance the below tools may be necessary:

- 1 Set of metric Allen keys
- 1 Set of screw drivers
- 1 Set of metric spanners
- 1 Wire stripper with long nose
- 1 Needle nose plier
- 1 Multi-meter (AC, DC, Resistance)

12 GENERAL INSTALLATION AND MAINTENANCE TIPS

For any installation and maintenance work, the following should be observed:

- Check the limit switch box visually. Ensure that no outside damages or changes are visible. The electric connecting cables must be without damage and wired correctly.
- Cable entries, cable glands, plugs etc. have to be checked for tightness.
- Check whether Ex-connections are fastened correctly.
- Take care of possible discolorations of the terminals and wires.
- Check the flame path gaps of flameproof enclosures for dirt and corrosion. Since the dimensions of all Ex gaps are strictly defined and inspected, no mechanical work shall be performed on them.
- Ensure that all enclosure seals are handled carefully and are being checked for damages. All cables and cable entry seals have to be checked.
- If defects are found during maintenance, repair measures must be taken immediately.
- Sealing surfaces must not be coated.
- Parts may only be exchanged by genuine parts.