

## ECON BUTTERFLY VALVES Series 63 and 64



**Series 63**



**Series 64**

**Content**

1. Introduction
2. ERIKS operating companies
3. Requirements for maintenance staff
4. Transport and storage
5. Application
6. Precautions to be taken prior to installation
7. Installation
8. Maintenance
9. Assembly and Disassembly
10. Function test
11. Service and repair
12. Troubleshooting
13. Removal

**1. Introduction**

In order to benefit from the excellent properties of the ECON butterfly valves it is necessary to follow the instructions of this user manual carefully. For errors resulting from improper installation the manufacturer or distributor can't be held responsible. Consult the applicable standards for allowable flange dimensions. Dimensions, materials and applicability of these valves should be derived from the technical ECON datasheets and documentation, which can be found in our latest catalogue or see our website [www.eriks.com](http://www.eriks.com) ECON Series 63 wafer type and 64 lug type butterfly valves.

**2. ERIKS operating companies**

ECON butterfly valves are being supplied by several ERIKS operating companies worldwide. In this manual these will be referred to as 'ERIKS', the individual terms of delivery of the ERIKS operating company having executed the order are applicable.

**3. Requirements for maintenance staff**

The staff assigned to assembly, operating and maintenance tasks should be qualified to carry out such jobs and in any circumstance, ensure personal safety.

**4. Transport and storage**

The valve must be transported and stored dry and clean. In humid rooms, a drying material or heating must be used to avoid condensation. During transport and intermediate storage the butterfly valve should not be outside a temperature range of -15°C and +30°C. The valve is supplied and has to be stored with the disc in a slightly open position (Fig.1). Do not remove the plastic bag covering the valve body before installation.

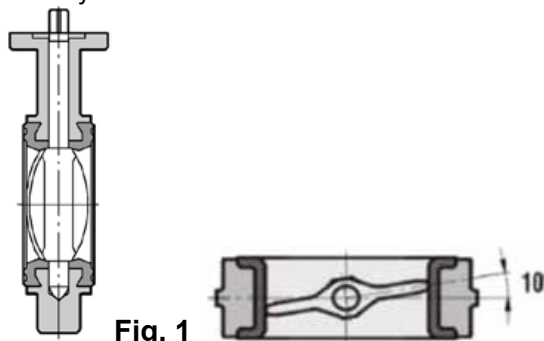

## 5. Application

Please make sure that the valve intended for installation is suitable for the service conditions prevailing. The ECON butterfly valves are used for industrial systems gases and liquids. The valves are designed for standard operating conditions. For the use of extreme conditions e.g. aggressive or abrasive media, it is recommended to mention this at the ordering stage, to verify whether the valve is suitable. The installation designer is responsible for the valve selection, suitable for the working conditions. The valves are unsuitable, without written permission of an ERIKS company, to apply for hazardous media as referred into Regulation (EC) No 1272/2008.

## 6. Precautions to be taken prior to installation

Please make sure that the valve intended for installation is suitable for the service conditions prevailing. The responsibility about the used fluids (corrosion resistance, pressure, temperature, etc.) lies by the user of the plant. Please consider that turbulences (i.e. created by piping bow) generate hydro dynamic forces increasing the operating torque of the valve. We recommend installing the valve minimum 5x DN after pipe fittings.

## 7. Installation

During the assembly of the ECON butterfly valves, the following rules should be observed:

- Make sure that the to be installed butterfly valve is suitable for the operating conditions (pressure / temp.) and is suitable for installation between the flanges.
- Never use a medium which could attack/damage the inside of the valve.
- Remove flange covers if present.
- The interior of valve and pipeline must be free from foreign particles.
- Preparing installation & Positioning: When installed in a horizontal pipeline it is recommended that the butterfly valve is to be mounted with the stem in a horizontal position, as such that the bottom of the disc will open in the direction of the flow. This way of mounting increases the lifetime of the valve and prevents sludging of the flow and accumulation of dirt. (See figure 2).
- Valves larger then DN300 may not to be mounted upside down (stem and ISO-top flange facing downwards).
- Gasket: Do not use a flange gasket or grease. (Fig. 3).
- Avoid damage to the rubber liner/seat during handling, storage and installation.
- The contact surfaces of the flanges must be smooth and clean and must have a smooth finish of Ra 3,2 to 12,5 micro meter.

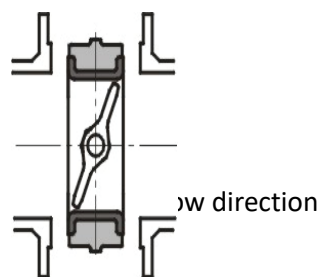

Fig. 2

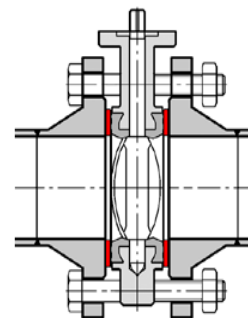
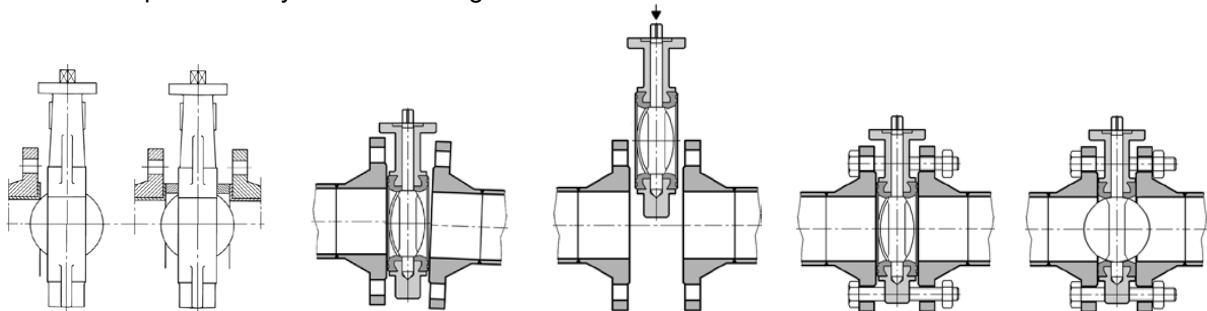

Fig. 3

- ERIKS recommends to mount rubber lined butterfly valves between flanges, which have the same inner diameter as the valves. This will extend the lifetime of the liner/seat and it will also create an optimal flange sealing. Flanges according to EN1092-2 type 11 do meet these requirements. Other types might cause difficulties. Flanges with a smaller bore than the valve itself, might damage the disc. Please use spacers when necessary. (Fig. 4). Under no circumstances should the valve be installed between non-parallel flanges. The axes of the pipeline and the butterfly valve must be aligned. The disc of an eccentrically mounted butterfly valve can be damaged (Fig. 5). It is also not allowed to

weld the pipeline if the valve is mounted between the flanges. This could permanently damage the valve. The flanges should have sufficient opening so that the valve can easily be placed between the flanges. The disc should be slightly open (Fig. 6). If the opening between flanges is too close the lining could be damaged. Insert the flange bolts while the disc is still a bit open and tighten the bolts by hand (Fig. 7). If the bolts are tightened while the valve is closed, the liner will be incorrectly tensioned. This will increase the torque and the valve can leak. Open the butterfly valve now completely (Fig. 8) and make sure the pipeline is aligned properly. Tighten the bolts evenly crosswise.

- Flexible gaskets are not allowed between butterfly body flange and counter flange..
- The butterfly valve must be installed in open position if possible, but the disc should not protrude beyond the housing.



**Fig. 4**

**Fig. 5**

**Fig. 6**

**Fig. 7**

**Fig. 8**

- Make sure that the weight of the butterfly valve, does not bend the pipeline which causes pipe stress. If necessary extra pipe supports need to be made.
- To prevent damage to the body of the valve due to reaction forces from the piping, no line tension may be transmitted to the valve.
- Lug type valves are suitable for temporarily dead-end services up to the maximum pressure rating of the valve for sizes up to DN200 (8"). Sizes DN250 (10") and larger can be used up to a maximal differential pressure of 6 bar (87 psi).
- In the event of an underground installation it must always be taken into account that there is a good support of the area, due to load forces from above.
- If mounted outside, the danger of snow and ice load could affect the operability of the valve, the user is responsible for proper precautions to prevent this from taking place
- Planners/construction companies or operators are responsible for positioning and installing products.
- Tighten the flange bolts in the sequence as shown in the below image, until the rubber is compressed and the pipe flanges touch the valve body.
- The maximum allowed bolt torque may never be exceeded!  
Check the information of your bolt supplier.
- Valve mountings such as actuators, worm gears or levers must not be used to take external forces, e.g. they are not to be used as climbing aids, or as connecting points for lifting gear.
- Before plant startup, especially after repairs carried out, flash out the pipeline.
- Don't open or close the valve too quickly, this can result in water hammer.
- We recommend to operate the valve at least once every two weeks.

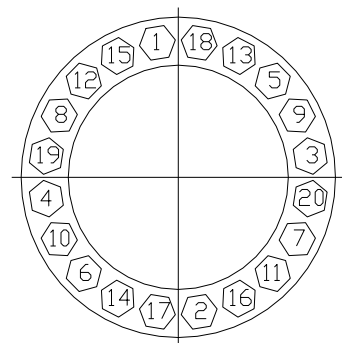

Bolt tightening sequence

## 8. Maintenance

The ECON butterfly valves have been designed and manufactured to obtain the maximum life and efficiency at minimum wear.

Before starting any service jobs, make sure that the medium supply to the pipeline is cut off, pressure was decreased to ambient pressure, the pipeline is completely cleaned and ventilated, and the plant is cooled down. Always keep safety instructions in mind and take all personal safety precautions.

No periodic lubrication or maintenance is required.

During maintenance, the following rules should be observed:

- always keep personal safety precautions in mind and always use appropriate protection e.g. clothing, masks, gloves etc.
- be alert that the temperature still can be very high or low and can cause burns.
- check the valve on all possible leaking possibilities.
- check if all bolts and nuts, are still fastened.
- dust, grease and medium residual, must be frequently cleaned of the valve body and all moving parts, such as stem to maintain all operating functions.

## 9. Disassembly and Assembly

### Disassembly

#### A. DN50 (2") – DN300 (12") Valve.

- Remove handle, manual gearbox or actuator from mounting flange.
- Open the valve and position the disc around 135 degree from the fully close position. The retainer pin is then exactly positioned inside the slot of the top flange.
- Remove the retainer pin with a screwdriver or any sharp tool.
- Pull out the stem from the body.
- Take out the disc and liner from the body.

#### B. DN350 (14") – DN600 (24") Valve.

- Remove manual gearbox or actuator from mounting flange.
- Remove the screws of upper cover. Remove the upper cover.
- Loose the bottom cover bolts, remove the bottom cover.
- Pull out both upper & lower stem from the body.
- Take out the disc and liner from the body.

### Assembly

#### A. DN50 (2") – DN300 (12") Valve

- Make sure the two bearings in the valve body, which support the stem near the disc, are still in position.
- Push the valve liner into an oval shape and push it into the body with the liner holes aligned to the body stem holes. Please be aware that the year and date marking on the liner (clock) must be pointing towards the top side (ISO-flange) of the valve. The upper liner hole is slightly larger than the bottom hole and will lead to stem leakage if mounted upside down!
- Insert stem top seal and bushing, and then push the stem into the stem hole of the body until the bottom of the stem is flush with the inner top edge of the liner.
- Apply a light coat of silicone lubricant on the I.D. of the liner. Insert the disc into the seat by lining up the disc hole with the stem hole of the seat. (Note: The broached spline hole in the disc must be pointing toward the bottom of the valve body) The disc is also marked with a small arrow which must point down to the bottom liner hole.
- With a downward pressure, the stem must be pushed back and forth, while rotating the disc, until the stem touches the bottom of the body stem hole.

- Make sure the dent located on top of the stem square is parallel to the disc, then pull out the stem slightly and replace the retainer pin and push back the stem.
  - Turn the disc clockwise to close position.
  - Reassemble the actuator and adjust the open and close position.
- B. DN350 (14") – DN600 (24") Valve.**
- Make sure the two bearings in the valve body, which support the stem near the disc, are still in position.
  - Push the valve liner into an oval shape and push it into the body with the liner holes aligned to the body stem holes. Please be aware that the year and date marking on the liner (clock) must be pointing towards the top side (ISO-flange) of the valve. The upper liner hole is slightly larger than the bottom hole and will lead to stem leakage if mounted upside down!
  - Insert stem top seal and bushing, and then push the stem into the stem hole of the body until the bottom of the stem is flush with the inner top edge of the liner.
  - Apply a light coat of silicone lubricant on the I.D. of the liner. Insert the disc into the seat by lining up the disc hole with the stem hole of the seat. (Note: The broached spline hole in the disc must point towards the top of the valve body) The disc is marked with a small arrow which must point down to the bottom liner hole.
  - With a downward pressure, the top stem must be pushed back and forth, while rotating the disc, until it cannot be pushed any further.
  - Use the same method in order to push in the bottom stem.
  - Make sure the dent located on top of the stem square is parallel to the disc, then pull out the stem slightly and replace the retainer pins and push the stem back in position.
  - Mount the retainer cover and fasten the screws.
  - Insert the pin to the lower stem, put back the O-ring and bottom cover. Fasten the cover.
  - Reassemble the actuator and adjust the open and close position.

Clock: Manufacturing year and month

Position: At top stem hole position!

Rubber material type

Valve size

Additional marking area: eg. FDA

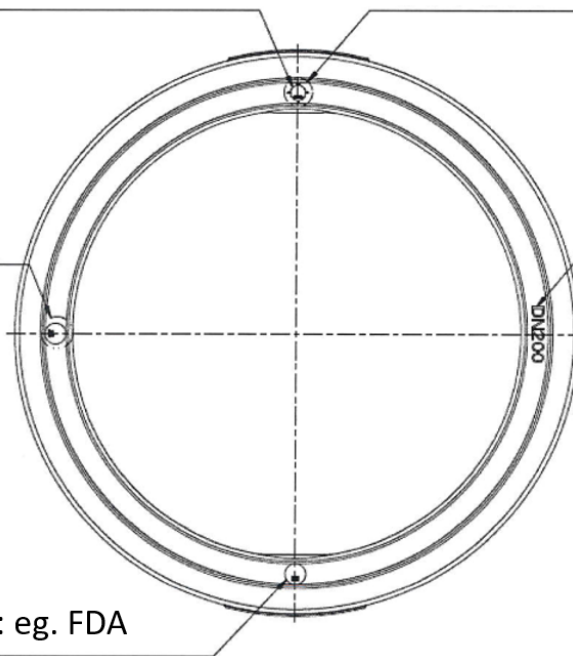

DN50 (2") - DN600 (24")

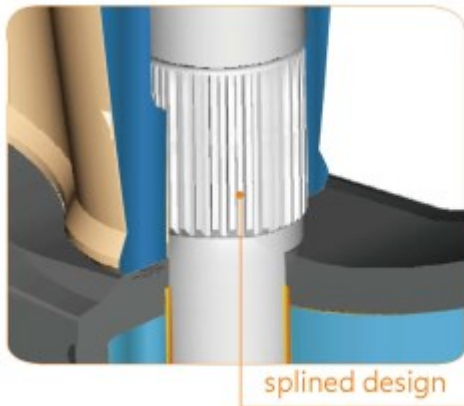

Disc and shaft are combined by a splined design.

#### **10. Function test**

It is recommended to perform a functional test before the butterfly valve is used for final operation. Hereby, the valve must be fully opened and closed to determine whether the valve runs smoothly and the flanges do not leak. If the pipe will be submitted to a pressure test the test pressure must not exceed the allowable operating pressure of the valve. Too high pressure may damage the valve.

#### **11. Service and repair**

All service and repair jobs should be carried out by authorized staff, using suitable tools and user shall use, bolt and nut of the same size and material as the original one.

- welding (repair) and drilling of the butterfly valve is forbidden.
- repair/overhaul of the valve is possible, but genuine parts must be used.
- during replacement of the butterfly valve, tighten the hexagon flange bolts (and nuts) evenly in crosswise order.
- after replacement of the butterfly valve, it is necessary to check the valve operation and tightness of all connections. A tightness test should be carried out.
- after installation, the valve should be checked and maintained periodically at least every 3 months, depending on the medium.



**Section view of the wafer type butterfly valve.**

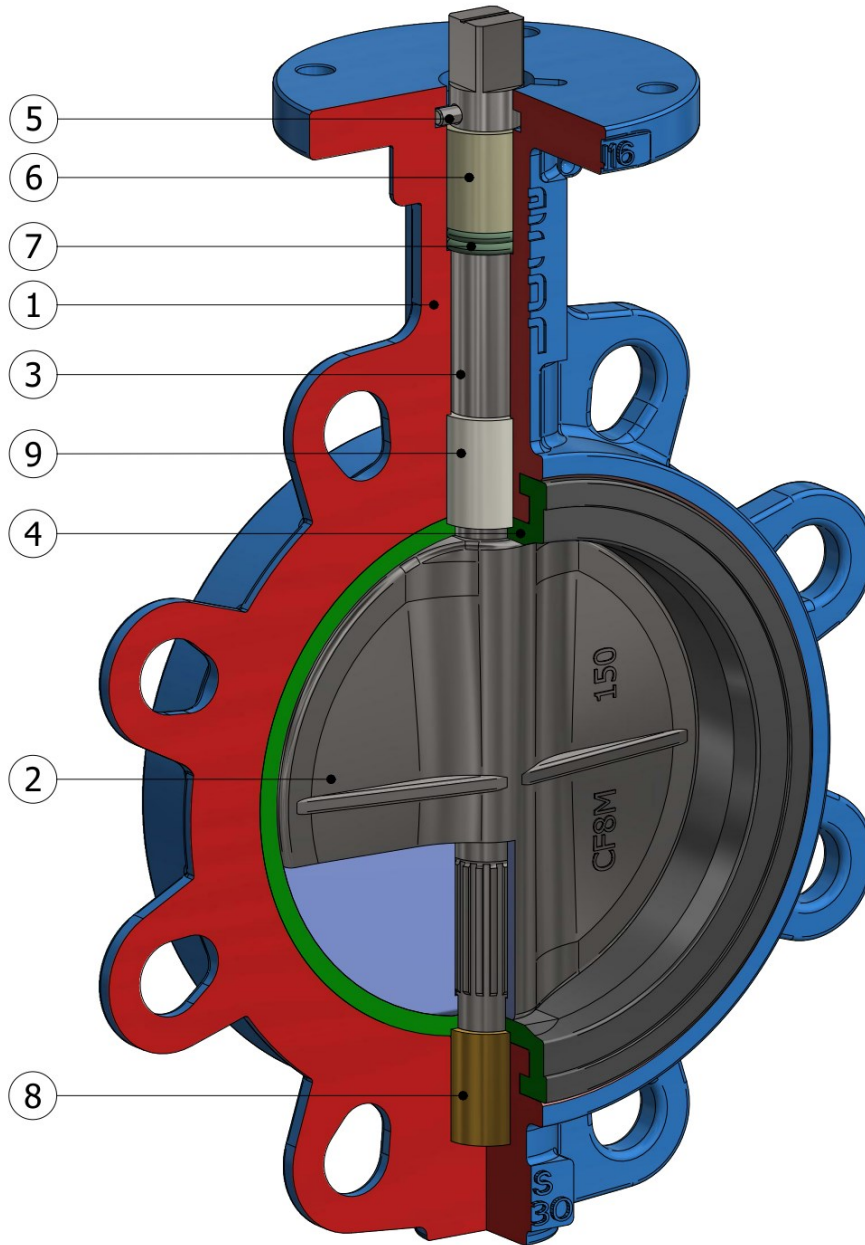

POS	DESCRIPTION	MATERIAL
1	BODY	EN-GJS-400-15 + EPOXY COATING
2	DISC	CuAl10Fe5Ni5-C (CC333G) / GX 5 CrNiMo 19-11-2 (1.4408)
3	SHAFT	1.4006 (AISI 410) up to DN200 and A182 F6A Class 3 for DN350-DN600
4	LINER	NBR-HT / EPDM-HT / FPM / EPDM-FDA
5	PIN	ASTM F182 F304
6	BUSH	DELRIN
7	O-RING	NBR
8	BUSH	ASTM B62
9	BUSH	RPTFE + A240 304



## 12. **Troubleshooting**

It is essential that the safety regulations are observed when identifying the fault.

<b>Problem</b>	<b>Possible cause</b>	<b>Corrective measures</b>
No flow	Flange dust caps were not removed	Remove dust caps
Little flow	Valve not completely open	Open valve completely
	Piping system clogged	Check piping system
Valve is impossible or difficult to open or close	Service conditions (e.g. medium, temperature) outside permissible limits.	Replace valve. Consult supplier.
	Power failure.	Check power supply.
	Wrong direction of rotation.	Turn in correct direction. (clockwise for opening)
	Fouling of the disc and/or seat	Remove fouling on the disc and/or seat
Valve leaking	Valve not properly closed	Close valve properly or readjust limit switch/stop screw.
	Seat damaged by foreign particles	Replace valve
	Medium contaminated	Clean valve and install dirt screen
Valve with locking device cannot be opened.	Locking device tightened	Slacken locking device.

## 13. **Removal**

All dismantled and rejected valves cannot be disposed with household waste. The valves are made of materials which can be re-used and should be delivered to designated recycling centres.

### **General warning:**

#### **General note for products which may be used for seawater:**

Although our products can be used in seawater systems it should always be noted that, in case of installation in a piping system made of materials which are frequently used because of their excellent seawater resistance (e.g. Cunifer), large potential differences may occur possibly causing corrosion which could permanently damage the proper functioning and integrity of our product.

A combination of different materials should always be mentioned prior to the purchase of our products in order for us to give the best possible advice on a safe functioning.