

EATON

Vickers

Q Series Piston Pumps

Variable Displacement, Quiet Series for Industrial Applications

Technical Catalog

PVQ10

PVQ13

PVQ20

PVQ25

PVQ32

PVQ40

PVQ45

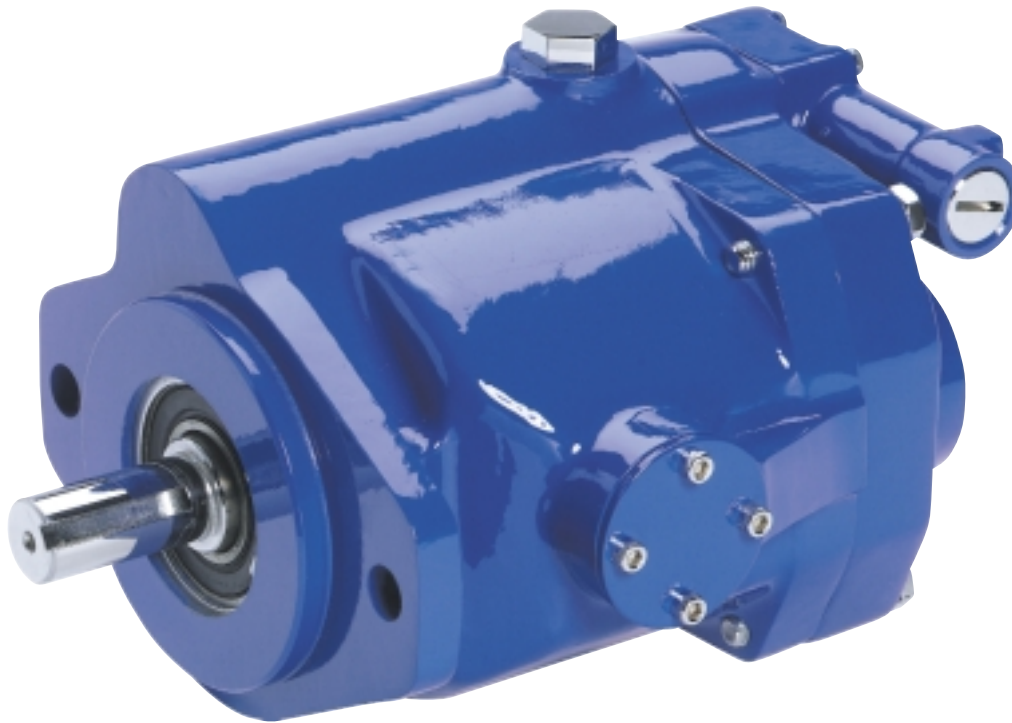

VICKERS[®]

Table of Contents

Introduction	3
PVQ10 and PVQ13	
Model Number System	4
Controls (Compensators)	6
Performance Curves	7
Operating Data	9
Installation Dimensions	10
Shaft Options	11
Controls	13
PVQ20 and PVQ32	
Model Number System	16
Controls (Compensators)	18
Performance Curves	19
Operating Data	19
Shaft Torque Data	21
Installation Dimensions	23
Controls	25
Thru-drives	29
PVQ25	
Model Number System	31
Controls (Compensators)	33
Performance Curves	34
Operating Data	35
Controls	36
Shaft Options	37
Controls	38
PVQ40 and PVQ45	
Model Number System	43
Controls (Compensators)	45
Performance Curves	46
Operating Data	48
Controls	49
Thru-drives	56
Application Data	60

Introduction

PVQ piston pumps are in-line, variable displacement units and are available in nine sizes. Displacement is varied by means of pressure and/or flow compensator controls. An impressive assortment of control options offers maximum operating flexibility.

PVQs operate at quietness levels that meet today's demanding industrial conditions. The sound level of each unit approaches or is below that of the electric motor driving it. Sound is reduced by a patented timing arrangement that also produces low pressure "pulses" in the outlet flow. This leads to reduced tendencies for noise in systems using PVQs.

The PVQ series is capable of operating with many types of hydraulic fluid. Water-content and phosphate ester fluids can be accommodated, in addition to the typical petroleum based and synthetic fluids.

Many PVQ pumps are available in a thru-drive configuration to accommodate a multitude of application and installation requirements. Thru-drive models can be coupled to various types and sizes of fixed and variable displacement pumps, resulting in a compact and versatile package. Such a package offers lower installed cost by reducing the installation size and by requiring only one mounting pad on the prime mover.

Quiet PVQs have excellent operating characteristics, and the pumps' many control and mounting options allow choosing the optimum model for any application. Additionally, PVQs possess the same durability and long life characteristics expected of the best industrial products in today's marketplace. For over 75 years, the Eaton name has been synonymous with long trouble-free service.

Operating Data Q Series Displacement, Speed, and Pressure Ratings

DISPLACEMENT, SPEED, AND PRESSURE RATINGS

Model Number System	Maximum Geometric Displacement cm ³ /r (in ³ /r)	Rated Speed r/min	Maximum Pressure bar (psi)
PVQ10	10,5 (0.643)	1800	210 (3000)
PVQ13	13,8 (0.843)	1800	140 (2000)
PVQ20	21,1 (1.290)	1800	210 (3000)
PVQ25	25,2 (1.540)	1800	210 (3000)
PVQ32	32,9 (2.010)	1800	140 (2000)
PVQ40	41,0 (2.500)	1800	210 (3000)
PVQ45	45,1 (2.750)	1800	186 (2700)

Application Data

- Fluid Cleanliness
- Hydraulic Fluids and Temperature Ranges
- Fire Resistant Fluids
- Installation and Start-up
- Ordering Procedure

Model Number System

PVQ10 and PVQ13

1	2	3	4	5	6	7	8	9	10	11	12	13	14	15	16	17	18	19	20	21	22	23	24	25	26	27	28
P	V	Q	1	0	A	2	R	S	E	1	S	2	0	C	*	2	1	V	*	1	1	B	D	1	2	S	*

Nos	Feature	Code	Description	Nos	Feature	Code	Description
1,2,3	Series PVQ	P V Q	Inline piston pump Variable volume Quiet series	15,16	Control type	C**V**B	Pressure compensator C** , as above with load-sensing. Standard load-sensing setting is 11 bar (160 psi); range 10-17 bar (150-250 psi); with bleed-down orifice. Example: C21V11B indicates PVQ10 compensator with 210 bar pressure setting and 11 bar load-sense differential.
4,5	Displacement in cc/rev and pressure ratings	10 13	10,5 cc/rev (0.64 cir), 210 bar (3000 psi) 13,8 cc/rev (0.84 cir), 140 bar (2000 psi)				
6,7	Mounting flange specifications	A2 MA	Flange SAE J744 82-2 (SAE A) Flange ISO 3019/2-80A2HW (available with "N" drive shaft only)			C**V**P	Pressure compensator with load-sensing as C**V**B above, but with bleed-down orifice plugged.
8	Rotation viewed from shaft end	R L	Right hand (cw), standard Left hand (ccw), optional				
9,10	Ports, type and location	SE SS	SAE O-ring rear port, 1.0625" inlet and outlet (standard) SAE O-ring side port, 1.3125" inlet and outlet (optional)			C**VC**B	Pressure compensator with load-sensing. Compensator same as C** above. Standard load-sensing setting is 24 bar (350 psi), range 17-31 bar (250-450 psi). With bleed-down orifice.
11	Shafts, input	1 3 N	Straight keyed SAE "A" modified, .75" dia. x 1.75" long Splined SAE "A" modified, 9T 16/32 DP major dia. fit Shaft end ISO 3019/2 E20N (available with "MA" mount only)			C**VC**P	Pressure compensator with load-sensing. Same as C**VC**B above, but with bleed-down orifice plugged.
12	Seals	S F	Buna N, standard Fluorocarbon, optional			CG	Pressure compensator modified for hydraulic remote control.
13,14	Pump design number	20	Design number subject to change. Installation dimensions remain unchanged for designs 10-19.			CD**	Electric dual range compensator. PVQ10: CD21 is standard 210 bar setting of high range (24-210 bar). PVQ13: CD14 is standard 140 bar setting of high range (24-140 bar). Both units require low range to be set by customer (20-100 bar).
15,16	Control type	C** CM**	Pressure compensator. PVQ10: Standard model is C21, indicating setting of 210 bar (3000 psi); range is 02-21 in tens of bar (350-3000 psi). PVQ13: Standard model is C14, indicating factory setting of 138 bar (2000 psi); range is 02-14 in tens of bar (350-2000 psi). Low pressure compensator. Standard model is CM7, indicating factory setting of 69 bar (1000 psi); range is 02-10 in tens of bar (350-1500 psi).			UV	Unloading Valve for accumulator circuits. See installation details.

Model Number System

PVQ10 and PVQ13

1	2	3	4	5	6	7	8	9	10	11	12	13	14	15	16	17	18	19	20	21	22	23	24	25	26	27	28
P	V	Q	1	0	A	2	R	S	E	1	S	2	0	C	*	2	1	V	*	1	1	B	D	1	2	S	*

Nos	Feature	Code	Description	Nos	Feature	Code	Description
17,18	Pressure setting	21 14	210 bar (3000 psi) PVQ10 140 bar (2000 psi) PVQ13	25,26	Control design	12	O-ring seal design
19,20	Flow control option	Blank V VC	No flow control	27,28	Special pump option suffixes	S2 S3	Shaft up mounting British Standard Parallel Threads Counterbore Ports (ISO R288 threads). Contact Eaton for available configurations.
21,22	Load sense differential pressure setting	Blank 11 24	No flow control			S9	Special CG compensator for use with electronically modulated relief valves.
23	Flow control option	Blank B P	No flow control				
24	Displacement option	Blank D	Without adjustable maximum displacement stop (standard). Adjustable maximum displacement stop (optional).				

RATINGS

Model Number System	Maximum Geometric Displacement cm ³ /r (in ³ /r)	Rated Speed r/min	Maximum Pressure bar (psi)	Input Power at Max. Pressure and Rated Speed kW (hp)	Approx. Weight kg (lb)
PVQ10	10,5 (0.643)	1800	210 (3000)	7,4 (10)	7,2 (16)
PVQ13	13,8 (0.843)	1800	140 (2000)	6,5 (8.75)	7,2 (16)

Pressure Limits:

Case pressure – 0,35 bar (5 psig) maximum
Inlet pressure – 0,2 bar (5 in. Hg) vacuum to 2 bar (30 psig)

Controls

Pressure Compensators

The pressure compensator control automatically adjusts pump delivery to maintain volume requirements of the system at a preselected operating pressure. Maximum pump delivery is maintained to approximately 3,4 bar (50 psi) below the pressure setting before being reduced. The pressure compensator control operates on one side of center and has an adjustment range as designated in the model numbering system.

Pressure Compensator with Adjustable Maximum Displacement Stop

The adjustable maximum stop pressure control enables the maximum pump delivery to be externally adjusted from 25% to 100% while maintaining all of the standard features of a pressure compensated pump. To assist initial priming, manual adjustment control setting must be at least 40% of maximum flow position.

Remote Control Pressure Compensator

Exactly the same as the "C" (pressure compensation option) except the machine operator is able to change the compensator setting through the use of a remote pilot relief valve, such as Eaton C-175.

Electric Dual Range Pressure Compensator

The dual range pressure compensator control automatically adjusts pump delivery to maintain volume requirements of the system at either of two preselected operating pressures. Maximum pump delivery is maintained to approximately 3,4 bar (50 psi) below either pressure control setting before being reduced.

Control type and pressure range are designated in the model number system.

Note: Graphic symbols shown with external valve(s) and cylinder to illustrate typical usage.

Load-sensing and Pressure Limiting Compensators

This compensator provides load-sensing control under all pressure conditions up to the desired maximum. It automatically adjusts pump flow in response to a remote pressure signal and maintains outlet pressure at a level slightly above load pressure. The integral pressure limiter overrides the load-sensing control, reducing pump displacement as the preset maximum operating pressure is reached.

Standard load-sense differential pressure settings, by control type, follow. See model number system for setting range.

Standard load-sensing and pressure limiting control with 11 bar differential pressure (standard factory setting). Includes bleed-down orifice to exhaust load-sense signal for low-pressure standby condition. Same as C**V11B above, but with bleed-down orifice plugged. Same as C**V11B, but with factory differential pressure setting of 24 bar. Same as C**V11P, but with factory differential pressure setting of 24 bar.

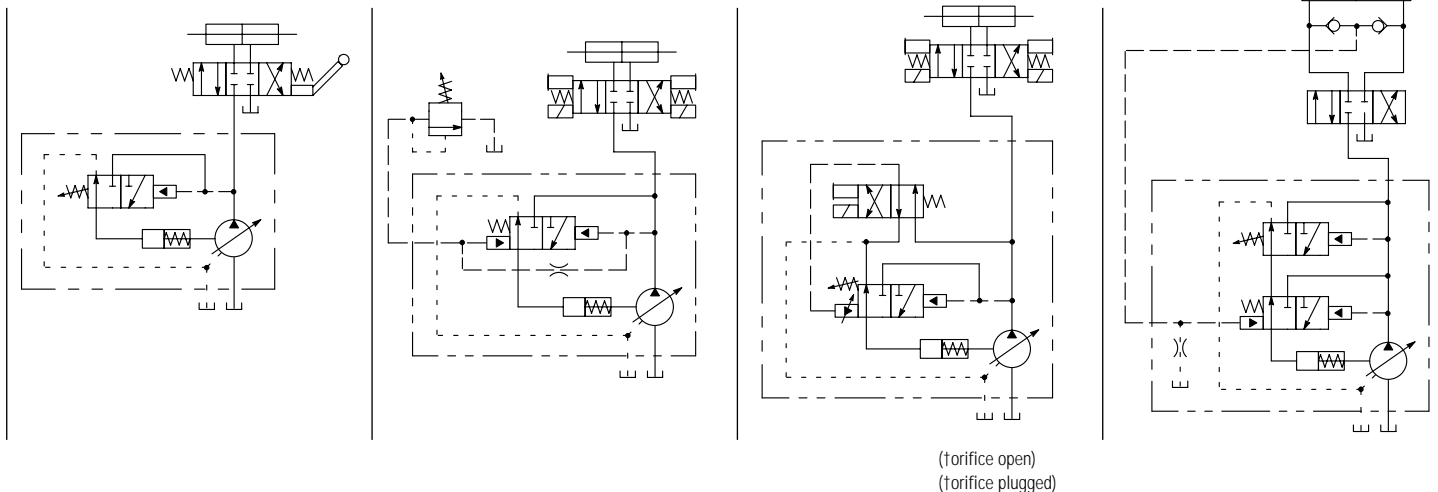

Performance Curves PVQ10

Oil type: SAE 10W
 Oil temperature: 49°C (120°F)
 Inlet: 0.2 bar (5 in. Hg)

Note: To obtain full flow operation of pump, pressure compensator setting must be 14 bar (200 psi) above desired operating pressure. Full flow curves were obtained with compensator settings 14 bar (200 psi) above 210 bar (3000 psi) max. rated pressure.

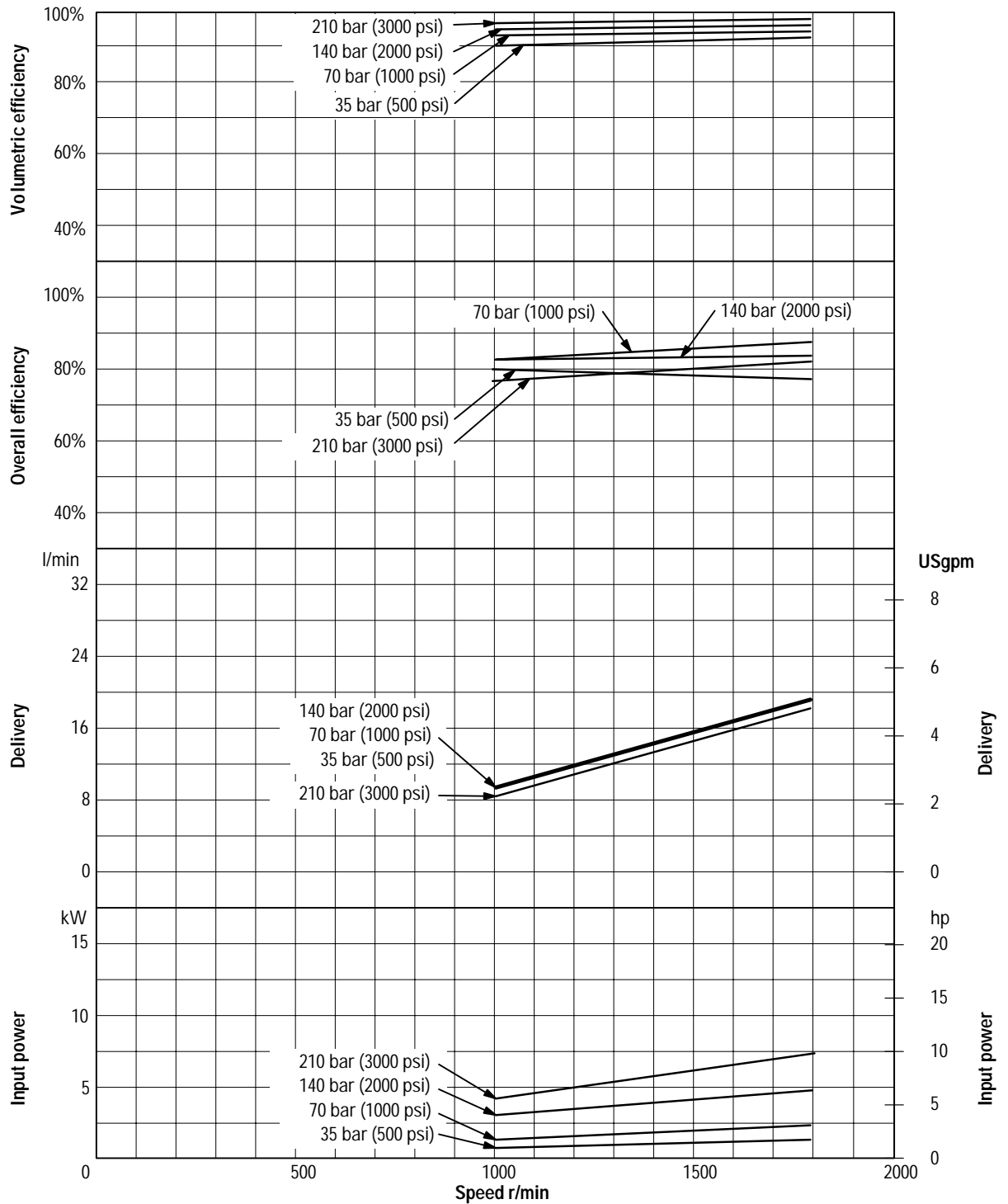

Performance Curves PVQ13

Oil type: SAE 10W
 Oil temperature: 49°C (120°F)
 Inlet: 0.2 bar (5 in. Hg)

Note: To obtain full flow operation of pump, pressure compensator setting must be 14 bar (200 psi) above desired operating pressure. Full flow curves were obtained with compensator settings 14 bar (200 psi) above 210 bar (3000 psi) max. rated pressure.

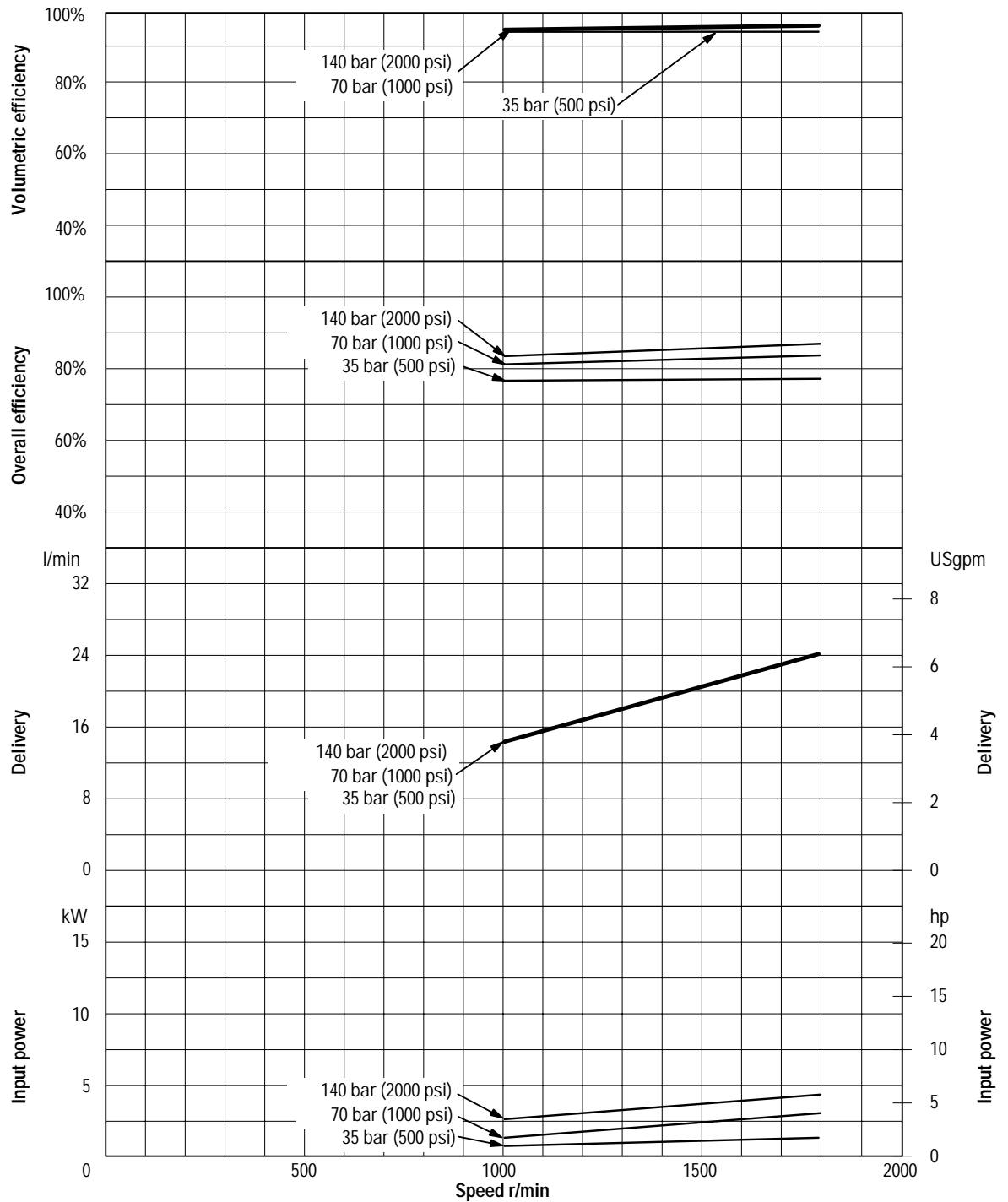

Operating Data PVQ10 and PVQ13 Sound Data

Temperature: 50°C (120°F)
Test Fluid: URSA-ED (10W)
Inlet Pressure: Atmospheric
(0 psig)

SOUND DATA

Speed r/min	Pressure bar (psi)	Sound Level dB(A)*			
		Full Stroke		Cutoff	
		PVQ10	PVQ13	PVQ10	PVQ13
1000	35 (500)	51	53	43	42
	70 (1000)	55	54	48	50
	100 (1500)	56	55	50	52
	140 (2000)	57	61	51	56
	175 (2500)	59	–	51	–
1200	35 (500)	53	54	46	44
	70 (1000)	55	54	49	52
	100 (1500)	56	58	51	56
	140 (2000)	57	65	53	57
	175 (2500)	60	–	54	–
1500	35 (500)	56	56	47	44
	70 (1000)	59	59	49	51
	100 (1500)	59	60	51	55
	140 (2000)	60	67	53	56
	175 (2500)	62	–	53	–
1800	35 (500)	58	58	52	49
	70 (1000)	60	61	53	56
	100 (1500)	62	63	55	58
	140 (2000)	63	–	57	–
	175 (2500)	65	–	57	–

*Sound pressure data equivalent to NFPA Standard.

Note: To ensure maximum noise reduction at full flow conditions, Engineering recommends limiting pressure of PVQ10 to 175 bar (2500 psi) and PVQ13 to 100 bar (1500 psi) at 1800 rpm.

PVQ10 and PVQ13 Response Data

Yoke response recorded at rated speed and pressure, 0 psi inlet, 82°C (180°F), SAE 10W oil. Pressure rise was 6900 bar (100,000 psi) per second.

RESPONSE DATA

Control Type	PVQ10	PVQ13	On stroke	Off stroke
	On stroke	Off stroke		
Pressure compensator	0.040 sec.	0.020 sec.	0.048 sec.	0.016 sec.

Installation Dimensions

PVQ10 and PVQ13 with Rear Ports

Millimeters (Inches)

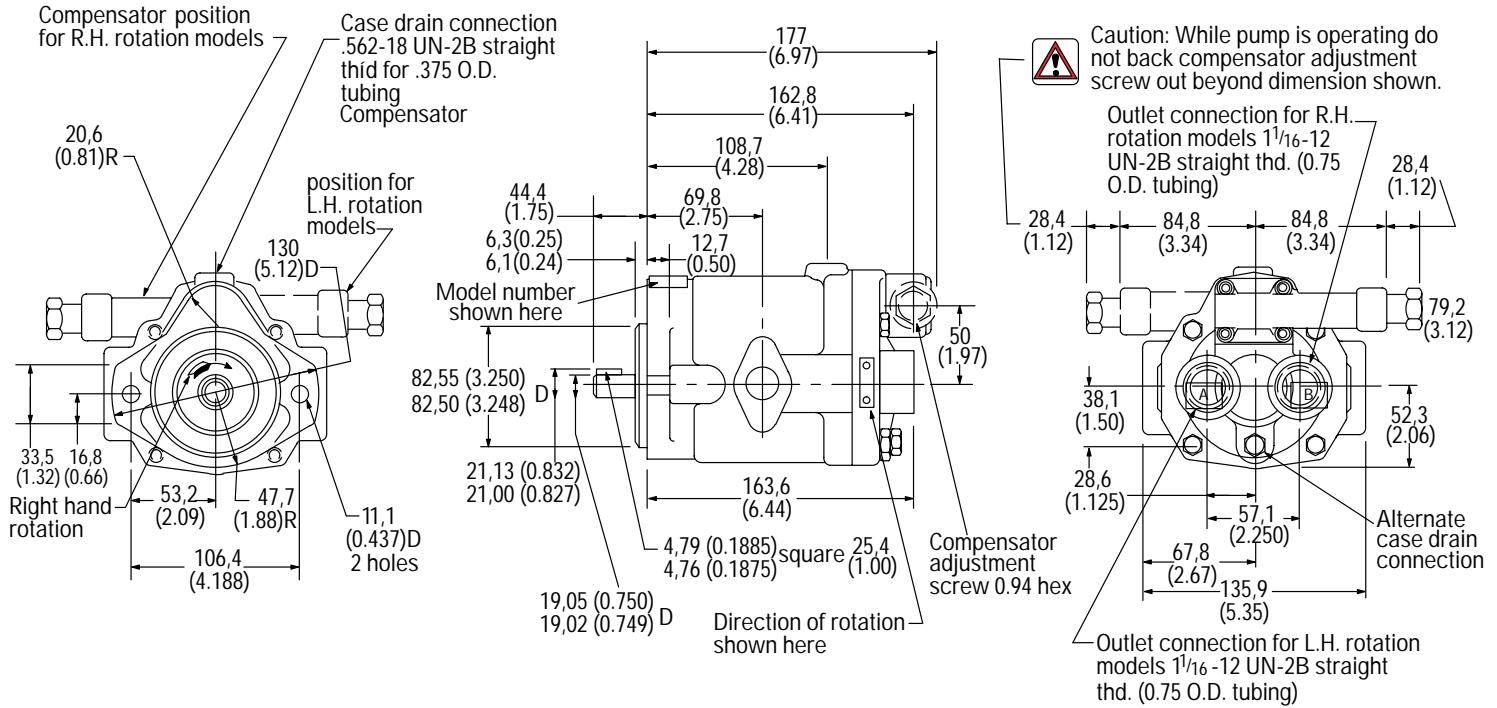

PVQ10 and PVQ13 with Side Ports

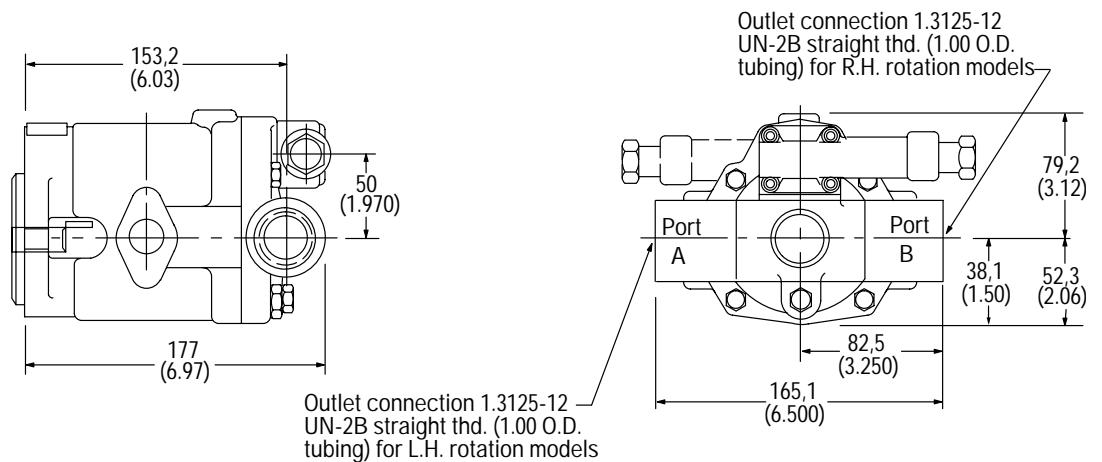

Shaft Options

No. 3 Shaft

"N" Shaft with "MA" Flange

(Flange and shaft end ISO 3019/2-80A2HW-E20N)

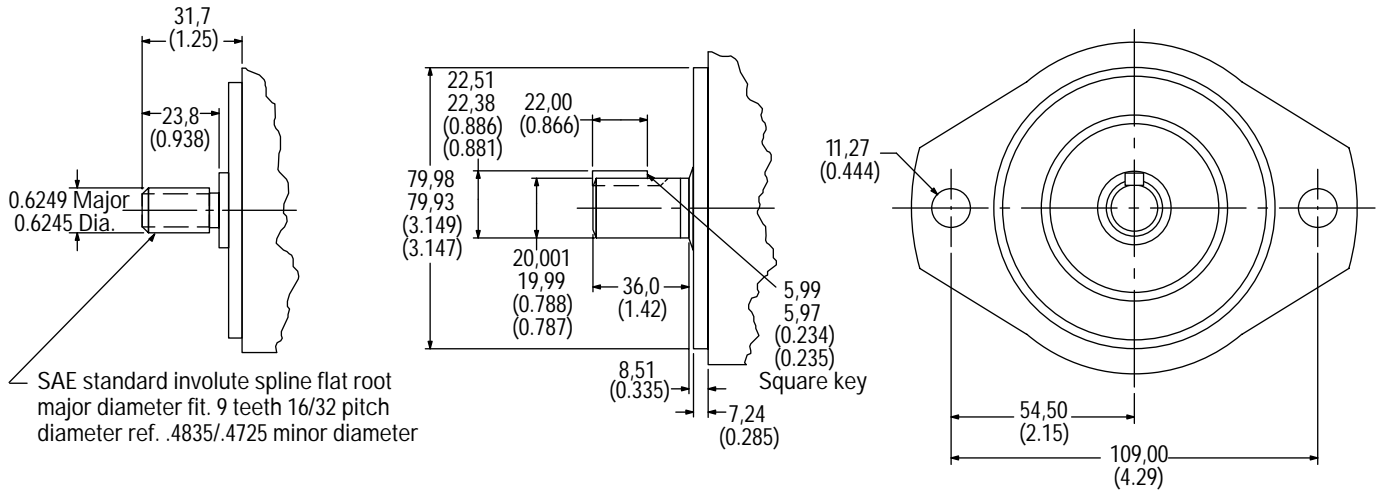

Controls Remote Compensator

Adjustment

1. Turn pressure control (such as C-175) CCW to minimum setting.
2. Turn compensator adjustment plug to desired minimum pressure (17 bar, 250 psi or higher).
3. Full pressure range can now be obtained with pressure control.

Caution: Effective compensator pressure will be compensator control setting (17-69 bar, 250-1000 psig) plus remote relief valve setting.

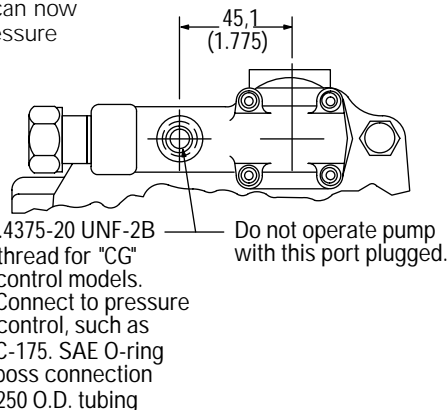

Load-sensing with Pressure Limiting Compensator

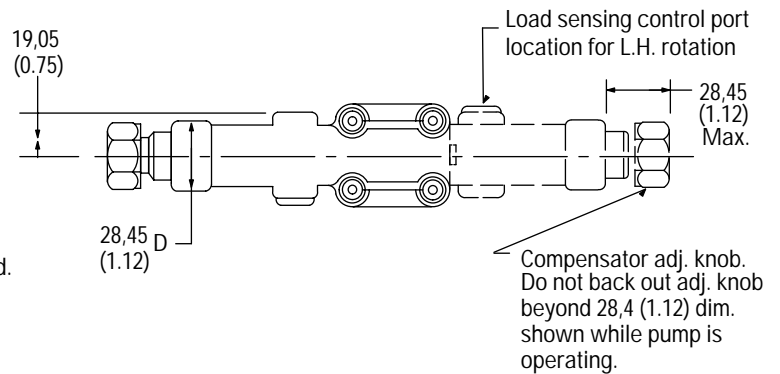
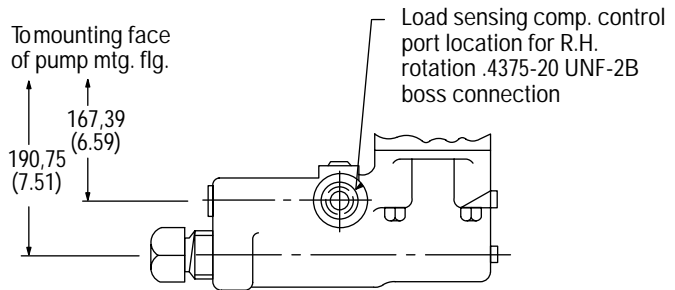

Shaft Options

No. 3 Shaft

"N" Shaft with "MA" Flange

(Flange and shaft end ISO 3019/2-80A2HW-E20N)

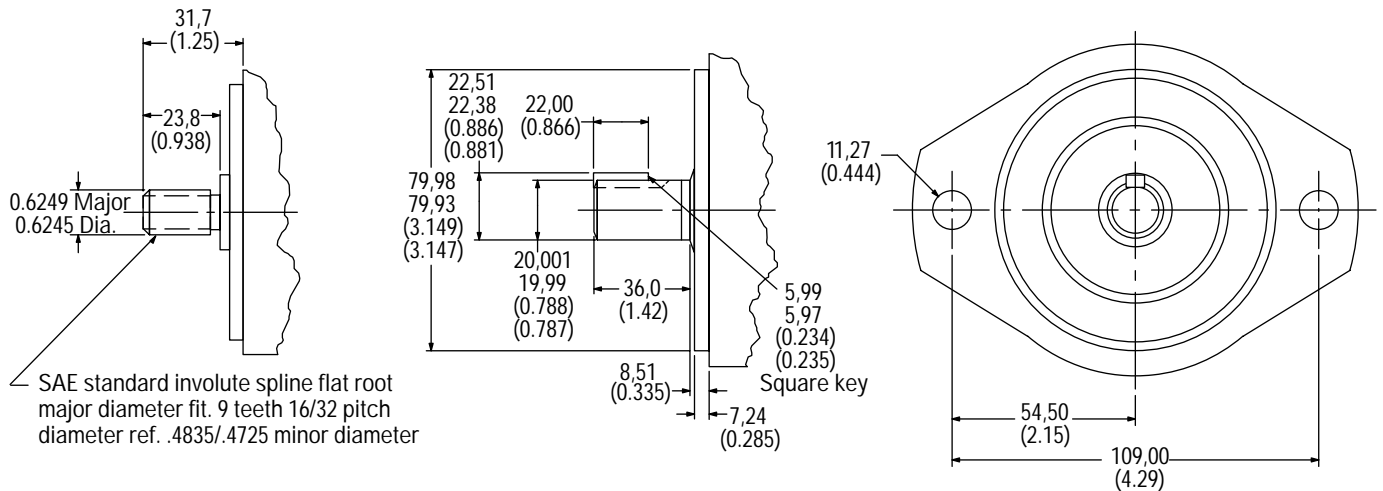

Controls Remote Compensator

Adjustment

1. Turn pressure control (such as C-175) CCW to minimum setting.
2. Turn compensator adjustment plug to desired minimum pressure (17 bar, 250 psi or higher).
3. Full pressure range can now be obtained with pressure control.

Caution: Effective compensator pressure will be compensator control setting (17-69 bar, 250-1000 psig) plus remote relief valve setting.

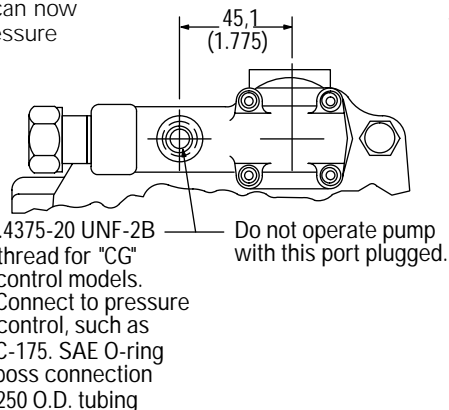

Load-sensing with Pressure Limiting Compensator

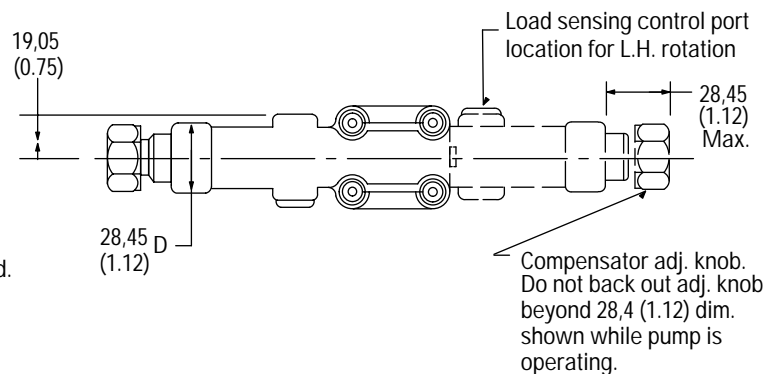
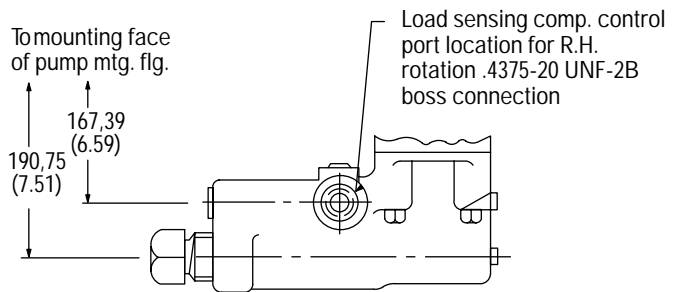

Controls Electric Dual Range Pressure Compensator Control

Adjustment

1. With the directional valve de-energized, loosen locknut " 5" and turn the adjusting screw " 4" to the desired first stage pressure setting, then tighten locknut " 5".
2. With solenoid de-energized, turn adjusting spool " 1" counterclockwise (CCW) until nut " 3" is bottomed in adjusting screw slot. (Second stage setting is now equal to first stage pressure setting.) Turn adjusting spool clockwise (CW) to desired second stage pressure requirements. One complete turn of adjusting spool equals approximately 41 bar (600 psi). Energize solenoid and check pressure setting. De-energize solenoid and re-adjust if necessary. Secure this setting by tightening locknut " 2".

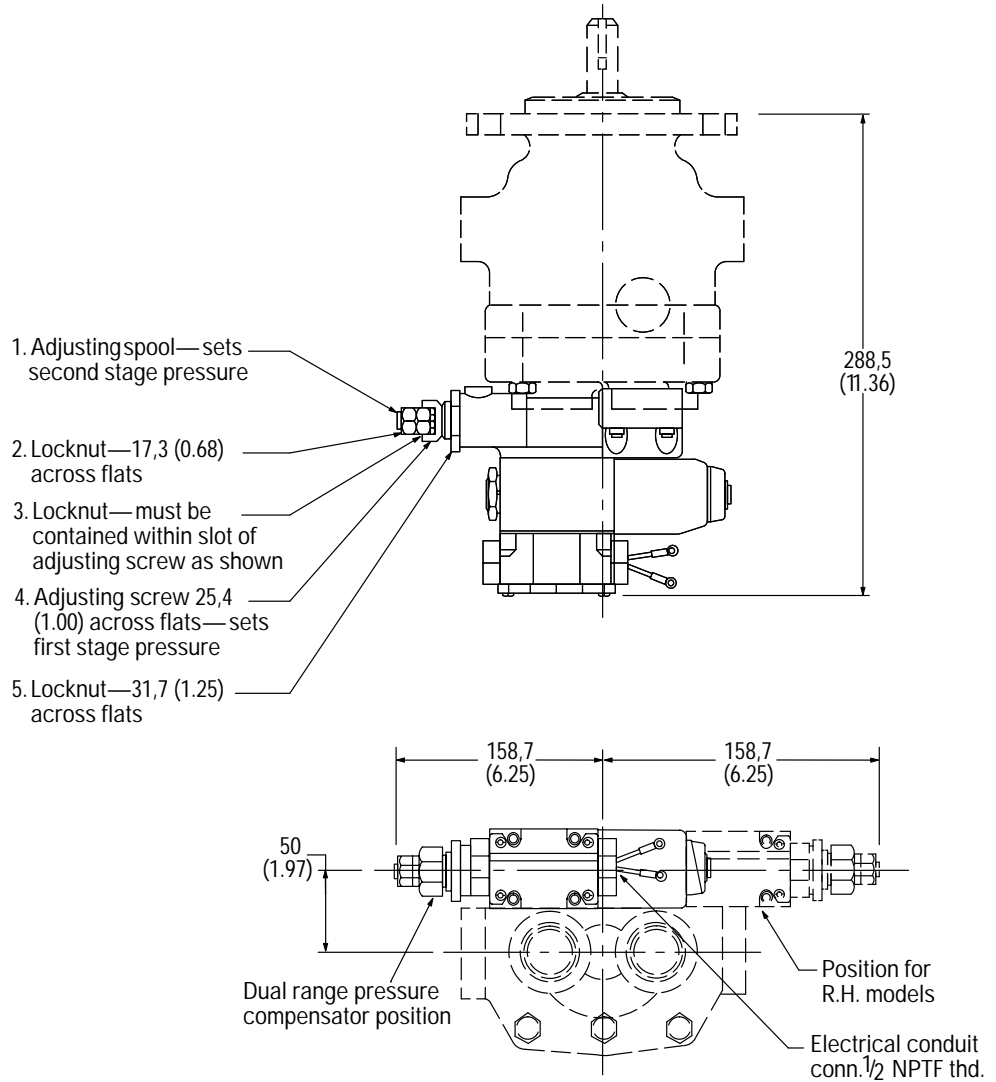

Solenoid Data (110V AC 50 Hz and 115/120V AC 60 Hz)

Solenoid current	Inrush amps (R.M.S.)	Holding amps
115/120V AC 60 Hz - 110V AC 50 Hz	2.0	.54 .64*

*Maximum peak inrush amps approximately 1.4 x R.M.S. value shown.
Refer to catalog GB-C-2015B for additional solenoid valve data.

Controls Electric Dual Range Pressure Compensator with Maximum Displacement Stop

Maximum Flow Adjustment

With the system pressure below both compensator settings, loosen maximum stop adjusting screw locknut and adjust screw to desired flow position (turning screw clockwise decreases flow and turning screw counterclockwise increases flow). To lock screw in position tighten locknut. To assist initial priming, adjust control setting to at least 40% of maximum flow position.

Compensator Control

1. With the directional valve de-energized, loosen locknut "5" and turn the adjusting screw "4" to the desired first stage pressure setting, then tighten locknut "5".
2. With directional valve de-energized, turn adjusting spool "1" counterclockwise until nut "3" is bottomed in adjusting screw slot. (Second stage setting is now equal to first stage pressure setting.) Turn adjusting spool clockwise to desired second stage pressure requirements. One complete turn of adjusting spool equals approximately 41 bar (600 psi). Energize solenoid and check pressure setting. De-energize solenoid and re-adjust if necessary. Secure this setting by tightening locknut "2".

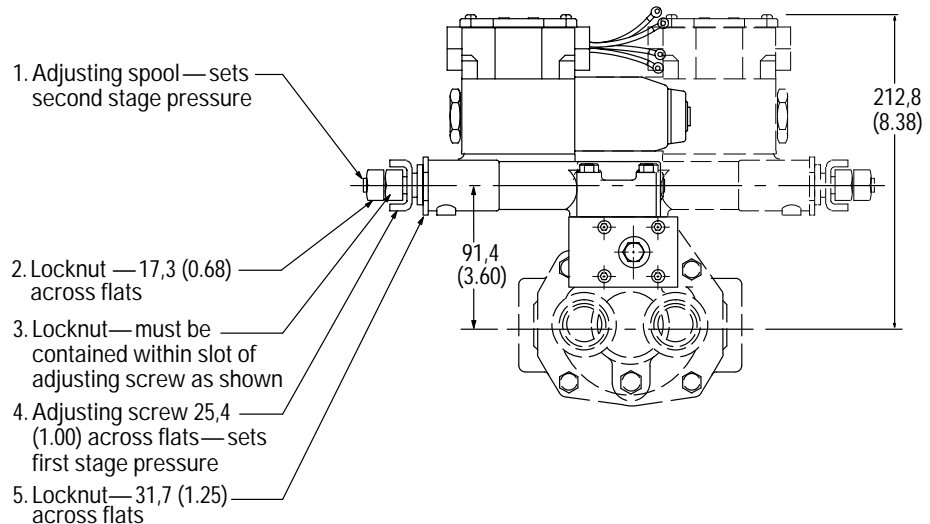
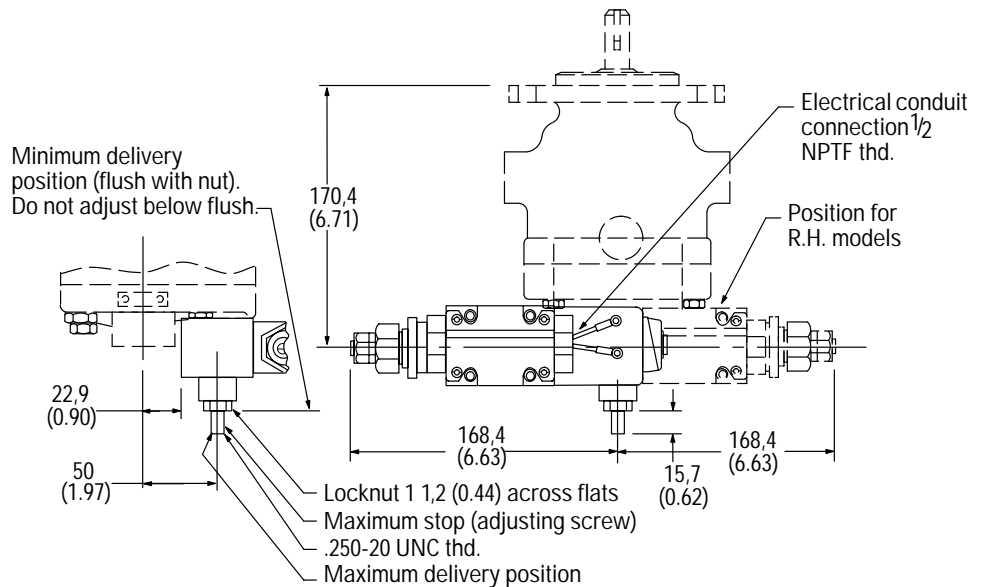

Controls

Unloading Valve Control

With the unloading valve control the variable pump will unload at a preset pressure. The pump will maintain this no flow, low pressure (approximately 14 bar [200 psi]) standby condition, until system pressure drops to about 85% of the preset unloading pressure. The pump will then return on stroke and provide full flow until the preset unloading pressure is reached again.

With this control, an efficient accumulator charging circuit is obtained. The pump will provide full flow to fill the accumulator until the maximum charging pressure is reached. The pump then goes to a standby condition until the accumulator pressure drops to 85% of the desired maximum. The accumulator is then recharged as the cycle starts over again.

A separate right angle check valve must be provided to maintain the accumulator hydraulic charge and prevent back flow when the pump is unloaded. The check valve's internal leakage must not exceed five drops per minute. The control port must be connected to system pressure, downstream of the check valve.

Adjustment range

PVQ10	100-210 bar (1500-3000 psi)
PVQ13	100-140 bar (1500-2000 psi)

Cut-in pressure is 85% of unloading pressure, minimum.

Setting Pressures

1. Back out accumulator unloading pressure adjustment screw to below desired unloading pressure.
2. Adjust desired standby pressure.
3. Set accumulator pressure by screwing in the accumulator unloading adjustment screw. Accumulator recharge (cut-in) pressure is a function of the maximum accumulator pressure and is not adjustable.
4. Check pressure settings and re-adjust if necessary.

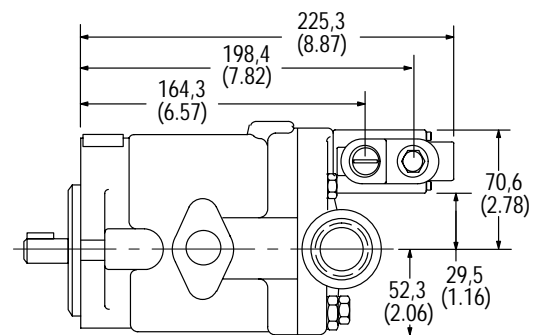
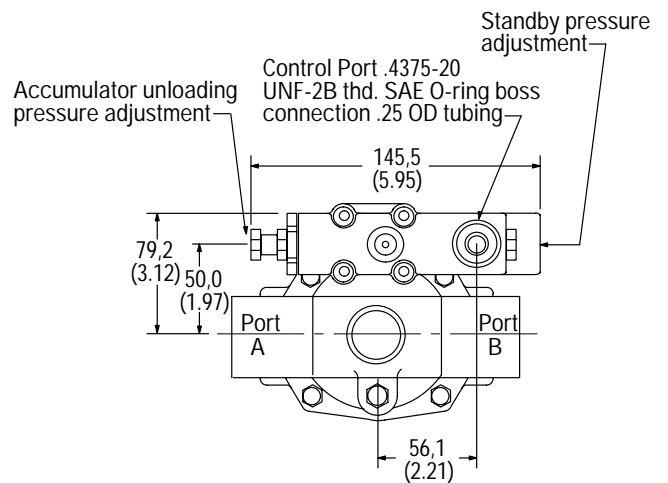
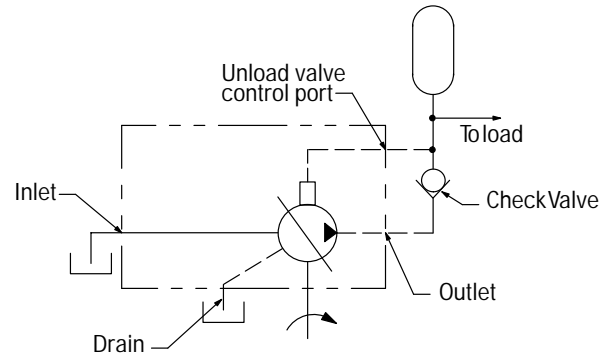

Model Number System

PVQ20 and PVQ32

1	2	3	4	5	6	7	8	9	10	11	12	13	14	15	16	17	18	19	20	21	22	23	24	25	26	27	28	29	30
P	V	Q	2	0	A	2	R	A	9	S	E	1	S	2	1	C	*	2	1	V	*	1	1	B	D	1	2	S	*

Nos	Feature	Code	Description	Nos	Feature	Code	Description
1,2,3	Series PVQ	P V Q	Inline piston pump Variable volume Quiet series			CM**	Low pressure compensator. Standard model is CM7, indicating factory setting of 70 bar (1000 psi); range is 02-10 in tens of bar (350-2000 psi).
4,5	Displacement in cc/rev and pressure ratings	20 32	21,1 cc/rev (1.29 cir), 210 bar (3000 psi) 32,9 cc/rev (2.01 cir), 140 bar (2000 psi)			C**V**B	Pressure compensator C**, as above with load-sensing. Standard load-sensing setting is 11 bar (160 psi); range 10-17 bar (150-250 psi); with bleed-down orifice. Example: C21V11B indicates PVQ20 compensator with 210 bar pressure setting and 11 bar load-sense differential.
6,7	Mounting flange specifications	B2 MB	Flange SAE J744 101-2 (SAE B) Flange ISO 3019/2-100A2HW (available with N" drive shaft only)			C**V**P	Pressure compensator with load-sensing as C**V**B above, but with bleed-down orifice plugged.
8	Rotation viewed from shaft end	R L	Right hand (cw), standard Left hand (ccw), optional			C**VC**B	Pressure compensator with load-sensing. Compensator same as C** above. Standard load-sensing setting is 24 bar (350 psi), range 17-31 bar (250-450 psi). With bleed-down orifice.
9,10	Thru-drive without coupling (available)	Blank A9 A11	No thru-drive SAE J744 82-2 (SAE A) w/9T spline with side ports only SAE J744 82-2 (SAE A) w/11T spline			C**VC**P	Pressure compensator with load-sensing. Same as C**VC**B above, but with bleed-down orifice plugged.
11,12	Ports, type and location	SE SS	SAE O-ring rear port, 1.625" inlet and outlet (standard) SAE O-ring side port, 1.625" inlet and outlet (optional)			CG	Pressure compensator modified for hydraulic remote control.
13	Shafts, input	1 3 N 28	Straight keyed SAE "B" modified, 2.31" long Splined SAE "B" modified, 13T 16/32 DP major dia. fit Shaft end ISO 3019/2 E25N (available with "MB" mount only) 26-tooth splined shaft (Eaton). Used in PVQ20/32 single to mount on PVQ40/45 "B26" thru-drive.			CD**	Electric dual range compensator. PVQ20: CD21 is standard 210 bar setting of high range (24-210 bar). PVQ32: CD14 is standard 140 bar setting of high range (24-140 bar). Both units require low range to be set by customer (20-100 bar).
14	Seals	S F	Buna N, standard Fluorocarbon, optional			UV	Unloading Valve for accumulator circuits. See installation details.
15,16	Pump design number	21	Design number subject to change. Installation dimensions remain unchanged for designs 10-19.				
17,18	Control type	C**	Pressure compensator. PVQ20: Standard model is C21, indicating setting of 210 bar (3000 psi); range is 02-21 in tens of bar (350-3000 psi). PVQ32: Standard model is C14, indicating factory setting of 138 bar (2000 psi); range is 02-14 in tens of bar (350-2000 psi).				

Model Number System PVQ20 and PVQ32

1	2	3	4	5	6	7	8	9	10	11	12	13	14	15	16	17	18	19	20	21	22	23	24	25	26	27	28	29	30
P	V	Q	2	0	A	2	R	A	9	S	E	1	S	2	1	C	*	2	1	V	*	1	1	B	D	1	2	S	*

Nos	Feature	Code	Description	Nos	Feature	Code	Description
19,20	Pressure setting	21 14	210 bar (3000 psi) PVQ20 140 bar (2000 psi) PVQ32	27,28	Control design	12 12 13 21	C** and CM** C**D and CM**D C**V(C)**B and C**V(C)**P UV, CD** CG 30
21,22	Flow control option	Blank V VC	No flow control	29,30	Special pump option suffixes	S2 S3	Shaft up mounting British Standard Parallel Threads Counterbore Ports (ISO R288 threads). Contact Eaton for available configurations.
23,24	Load sense differential pressure setting	Blank	No flow control			S9	Special CG compensator for use with electronically modulated relief valves
25	Flow control optional features	Blank B P	No flow control				
26	Control option	Blank D	Without adjustable maximum displacement stop (standard) Adjustable maximum displacement stop (optional)				

RATINGS

Model Number System	Maximum Geometric Displacement cm ³ /r (in ³ /r)	Rated Speed r/min	Maximum Pressure bar (psi)	Input Power at Max. Pressure and Rated Speed kW (hp)	Approx. Weight kg (lb)
PVQ20	21,1 (1.290)	1800	210 (3000)	14,9 (20)	14 (31)
PVQ32	32,9 (2.010)	1800	140 (2000)	15,6 (21)	14 (31)

Pressure Limits:

Case pressure – 0,35 bar (5 psig) maximum
Inlet pressure – 0,2 bar (5 in. Hg) vacuum to 2 bar (30 psig)

Controls

Pressure Compensator Controls

The pressure compensator control automatically adjusts pump delivery to maintain volume requirements of the system at a preselected operating pressure. Maximum pump delivery is maintained to approximately 75 psi (PVQ20) or 100 psi (PVQ32) below the pressure setting before being reduced. The pressure compensator control operates on one side of center and has an adjustment range as designated in the model numbering system.

Pressure Compensator Control with Adjustable Maximum Displacement Stop

The adjustable maximum stop pressure control enables the maximum pump delivery to be externally adjusted from 25% to 100% while maintaining all of the standard features of a pressure compensated pump. To assist initial priming, manual adjustment control setting must be at least 40% of maximum flow position.

Remote Control Pressure Compensator

Exactly the same as the "C" (pressure compensation option) except the machine operator is able to change the compensator setting through the use of a remote pilot relief valve, such as Eaton C-175.

Electric Dual Range Pressure Compensator Control

The dual range pressure compensator control automatically adjusts pump delivery to maintain volume requirements of the system at either of two preselected operating pressures.

Maximum pump delivery is maintained to approximately 75 psi (PVQ20) or 100 psi (PVQ32) below either pressure control setting before being reduced.

Control type and pressure range are designated in the model number system.

Note: Graphic symbols shown with external valve(s) and cylinder to illustrate typical usage.

Load-sensing and Pressure Limiter Compensator Control

This compensator provides load-sensing control under all pressure conditions up to the desired maximum. It automatically adjusts pump flow in response to a remote pressure signal and maintains outlet pressure at a level slightly above load pressure. The integral pressure limiter overrides the load-sensing control, reducing pump displacement as the preset maximum operating pressure is reached.

Standard load-sense differential pressure settings, by control type, follow. See model number system for setting range.

Standard load-sensing and pressure limiting control with 11 bar differential pressure (standard factory setting). Includes bleed-down orifice to exhaust load-sense signal for low-pressure standby condition.

Same as C**V11B above, but with bleed-down orifice plugged.

Same as C**V11B, but with factory differential pressure setting of 24 bar.

Same as C**V11P, but with factory differential pressure setting of 24 bar.

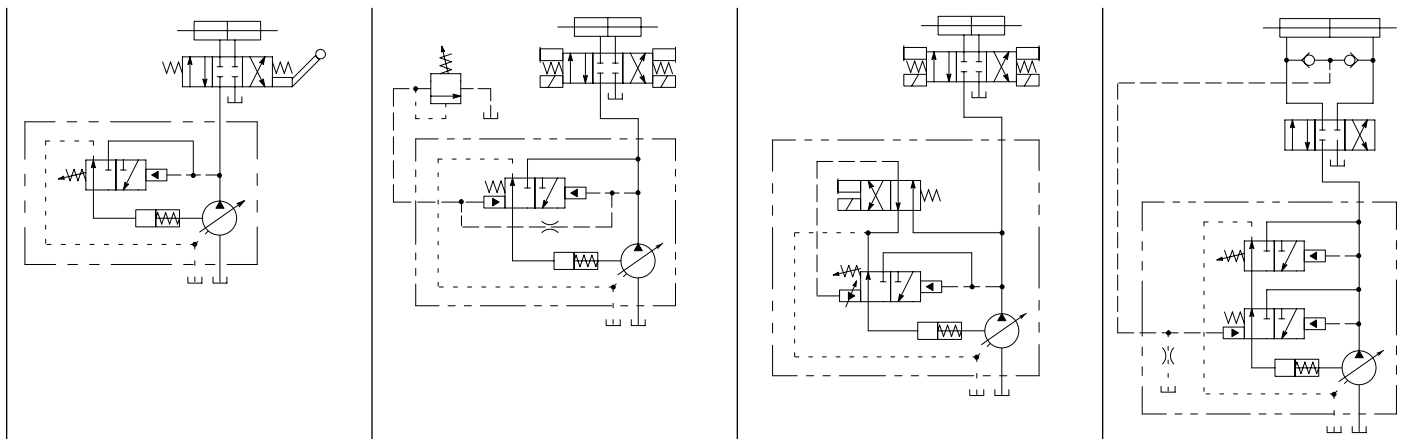

(torifice open)
(torifice plugged)

Performance Curves

PVQ20

Oil type: SAE 10W
 Oil temperature: 49°C (120°F)
 Inlet: 0.2 bar (5 in. Hg)

Note: To obtain full flow operation of pump, pressure compensator setting must be 14 bar (200 psi) above desired operating pressure. Full flow curves were obtained with compensator settings 14 bar (200 psi) above 210 bar (3000 psi) max. rated pressure.

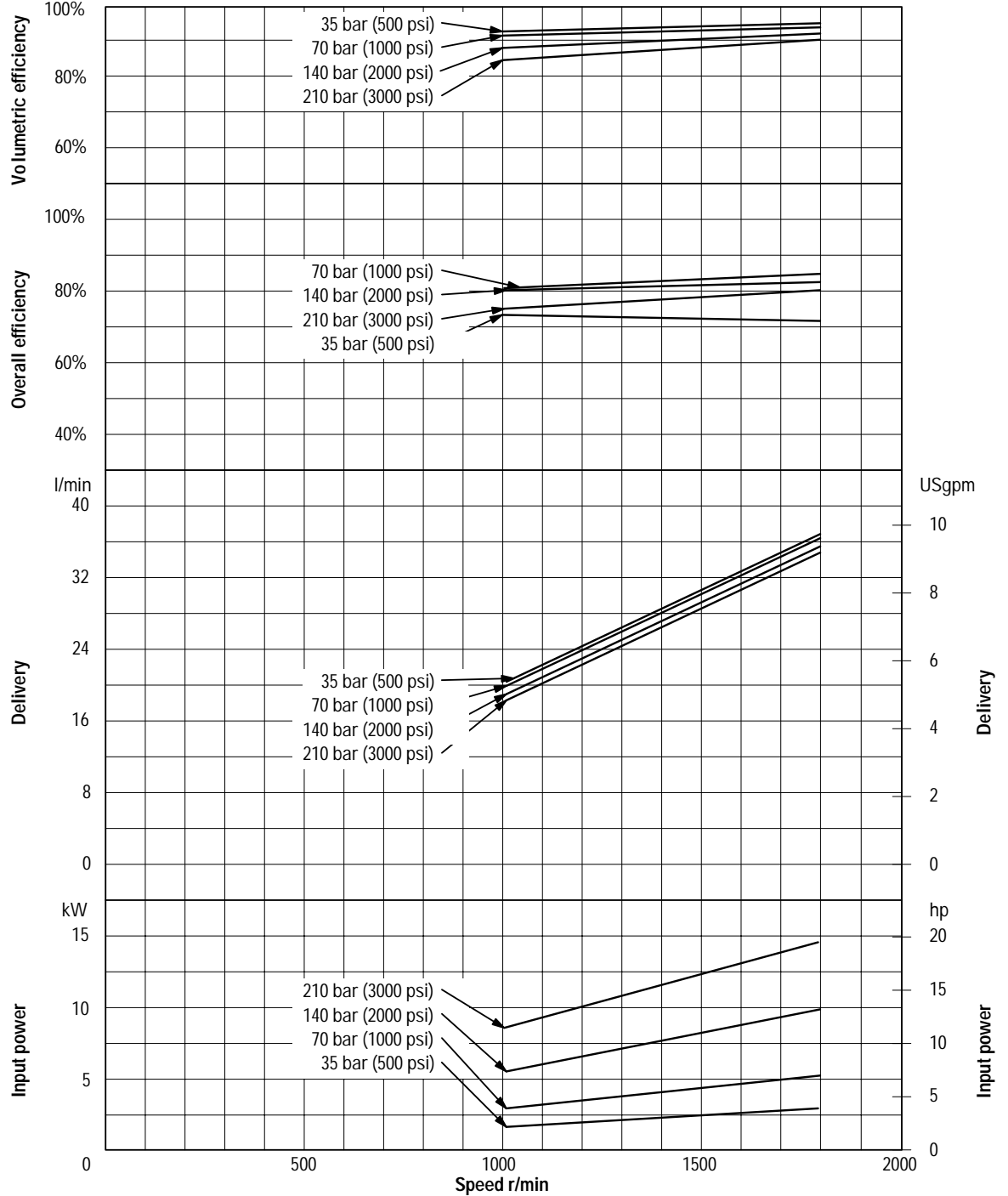

Performance Curves PVQ32

Oil type: SAE 10W
 Oil temperature: 49°C (120°F)
 Inlet: 0.2 bar (5 in. Hg)

Note: To obtain full flow operation of pump, pressure compensator setting must be 14 bar (200 psi) above desired operating pressure. Full flow curves were obtained with compensator settings 14 bar (200 psi) above 140 bar (2000 psi) max. rated pressure.

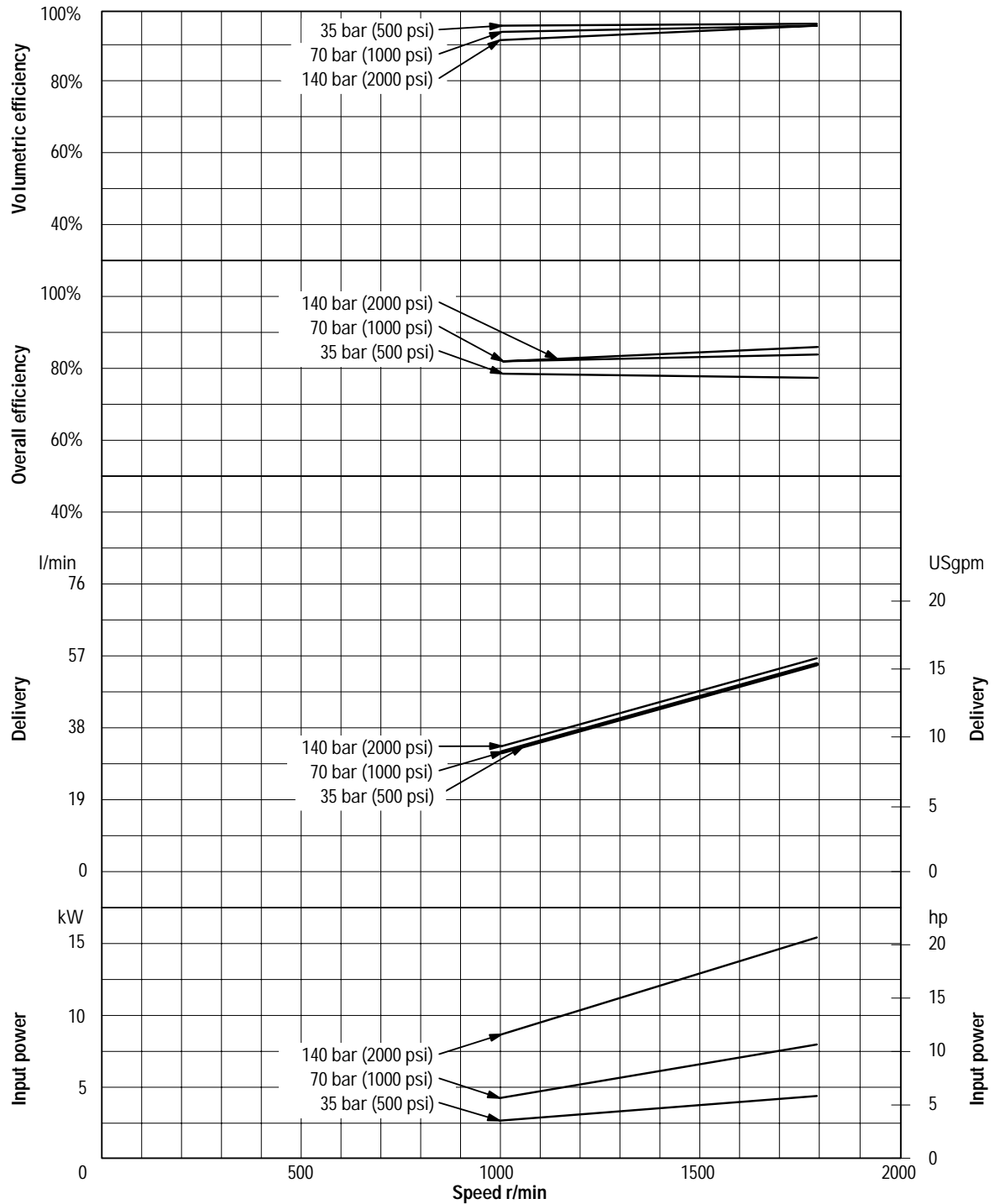

Operating Data

PVQ20 and PVQ32 Sound Data

Temperature: 50°C (120°F)
 Test Fluid: URSA-ED (10W)
 Inlet Pressure: Atmospheric
 (0 psig)

SOUND DATA

Speed r/min	Pressure bar (psi)	Sound Level dB(A)*			
		Full Stroke		Cutoff	
		PVQ20	PVQ32	PVQ20	PVQ32
1000	35 (500)	53	58	43	47
	70 (1000)	56	59	47	50
	140 (2000)	57	61	52	54
	210 (3000)	59	–	54	–
1200	35 (500)	55	61	43	47
	70 (1000)	58	62	48	51
	140 (2000)	59	63	52	54
	210 (3000)	61	–	55	–
1500	35 (500)	57	63	47	50
	70 (1000)	59	65	51	54
	140 (2000)	61	65	56	55
	210 (3000)	62	–	59	–
1800	35 (500)	60	66	50	53
	70 (1000)	62	67	53	56
	140 (2000)	63	68	58	62
	210 (3000)	64	–	58	–

*Sound pressure data equivalent to NFPA Standard.

PVQ20 and PVQ32 Response Data

Yoke response recorded at
 rated speed and pressure, 0 psi
 inlet, 82°C (180°F), SAE 10W oil.
 Pressure rise was 6900 bar
 (100,000 psi) per second.

RESPONSE DATA

Control Type	PVQ20		PVQ32	
	On stroke	Off stroke	On stroke	Off stroke
Pressure compensator	0.070 sec.	0.023 sec.	0.080 sec.	0.020 sec.
load-sense compensator	0.090 sec.	0.015 sec.	0.100 sec.	0.018 sec.

Shaft Torque Data

PVQ20/32A9 and PVQ20/32A11

Thru-drive Shaft Torque Data

Any deviation from these maximum torque values must be approved by Eaton engineering.

THRU-DRIVE SHAFT TORQUE DATA

Model Number System*	Input Shaft Code	Maximum Input Torque Total Nm (lb. in.)	Maximum Thru-drive Torque Output Nm (lb. in.)
PVQ20/32A9	1	135 (1200)	
	3	208 (1850)	58 (517)
	N	337 (2987)	
PVQ20/32A11	1	135 (1200)	
	3	208 (1850)	123 (1100)
	N	337 (2987)	

*SAE "B" 4 inch thru-drive pilot not available in PVQ20/32 frame size.

Installation Dimensions

Vertical "Shaft-up" Installation - "S2" Drain Port Option

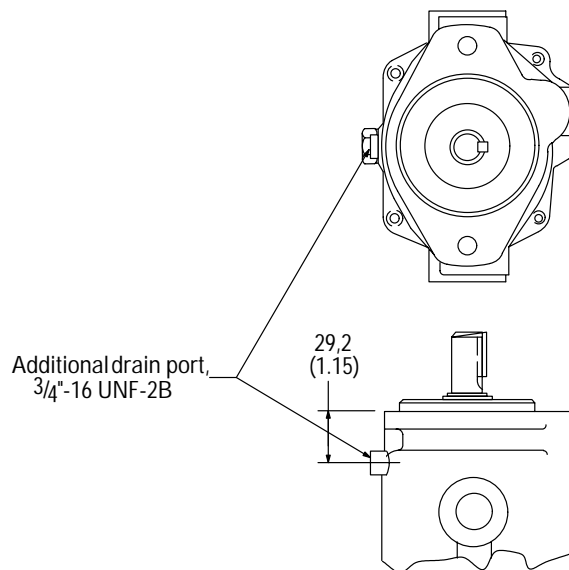

Installation Dimensions

Rear Ports, "C" and "CM" Controls, No. 1 Shaft

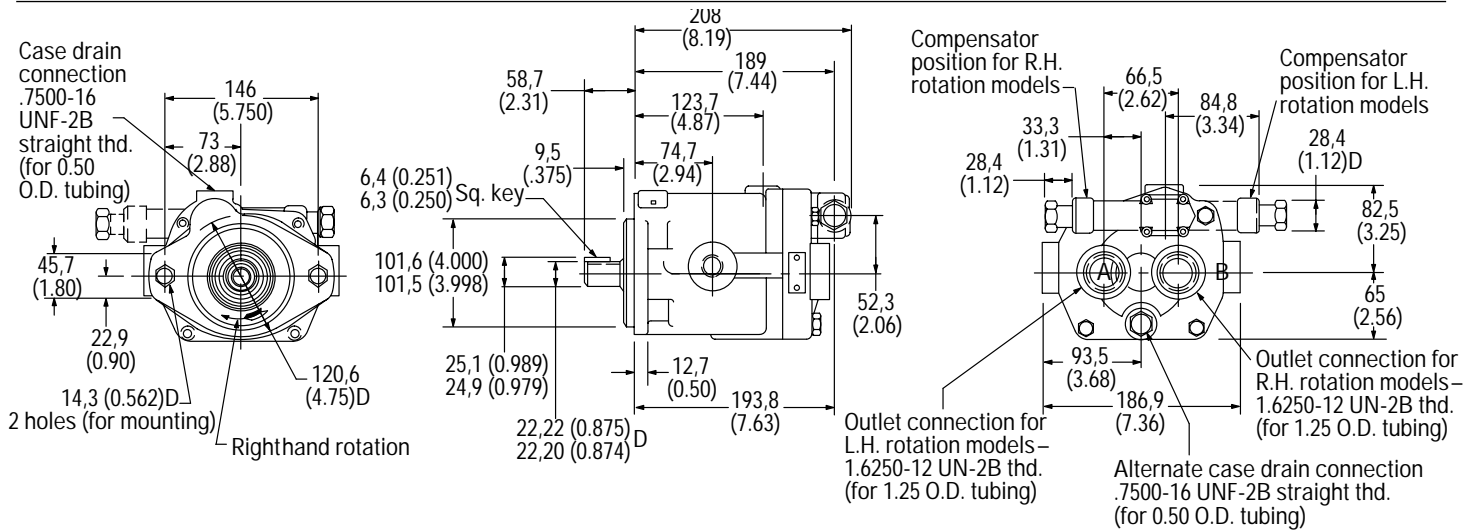

Caution – while pump is operating do not back compensator adjustment screw out beyond dimension shown.

Installation Dimensions

Side Ports

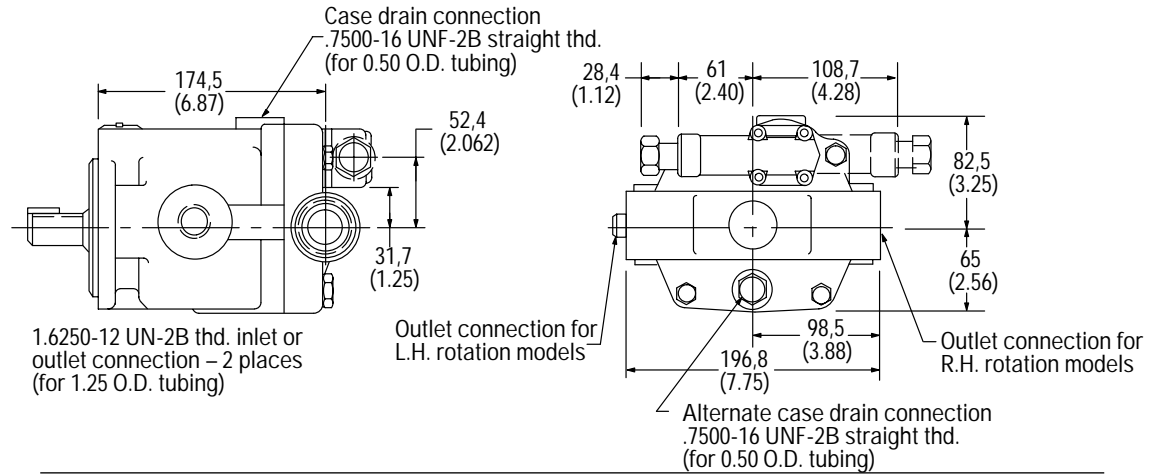

No. 3 Shaft

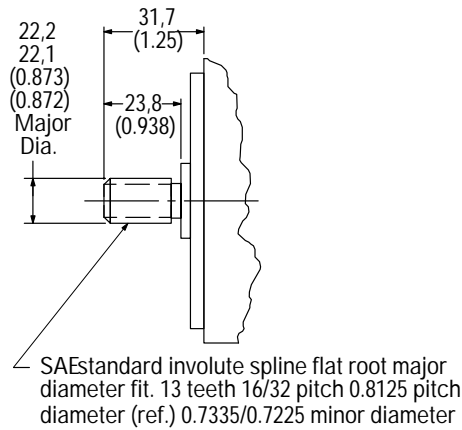

“N” Shaft with “MB” Flange

(Flange and shaft end ISO 3019/21000A2HW-E25N)

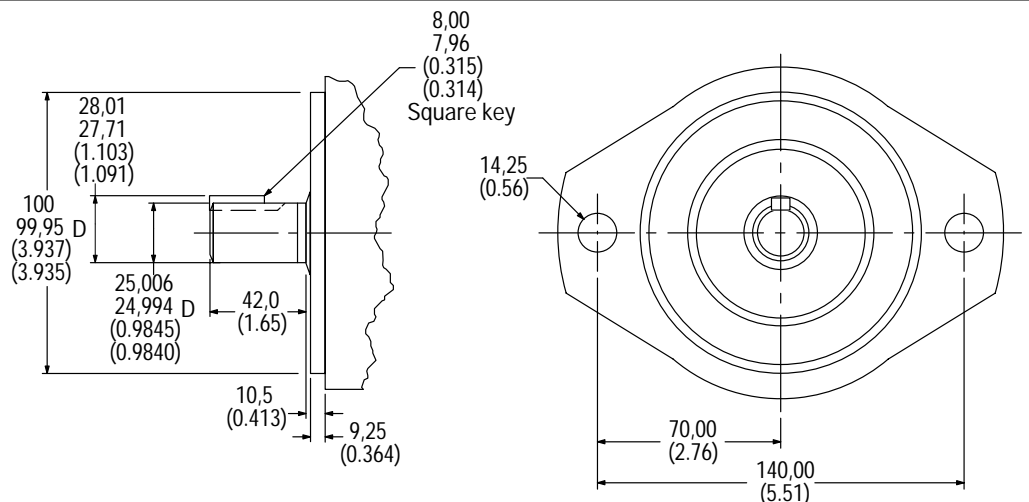

Remote Compensator

Adjustment

1. Turn pressure control (such as C-175) CCW to minimum setting.
2. Turn compensator adjustment plug to desired minimum pressure (17 bar, 250 psi or higher).
3. Full pressure range can now be obtained with pressure control.

Caution: Effective compensator pressure will be compensator control setting (17-69 bar, 250-1000 psig) plus remote relief valve setting.

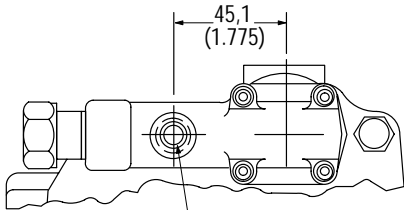

.4375-20 UNF-2B thread for "CG" control models. Do not operate pump with this port plugged. Connect to pressure control, such as C-175. SAE O-ring boss connection .250 O.D. tubing

Load-sensing with Pressure Limiter

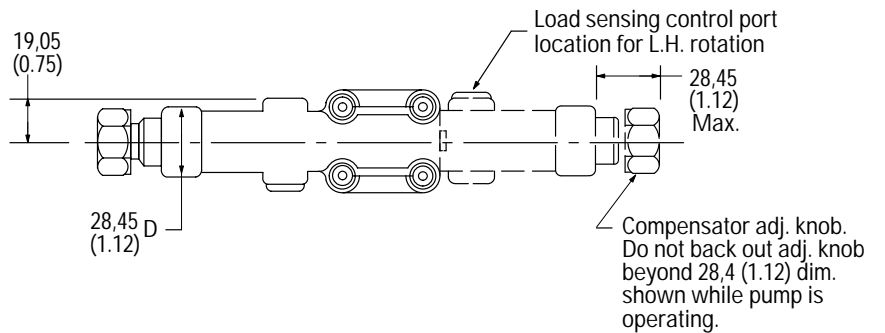
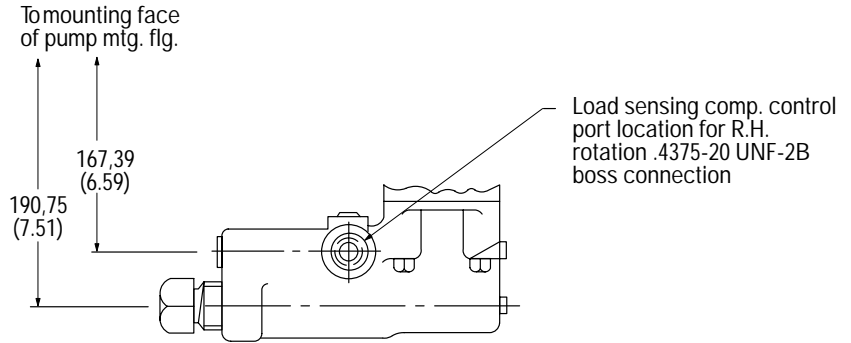

Pressure Compensator Control with Adjustable Max. Displacement Stop

Adjustment

Loosen locknut on adjusting rod. Turn adjusting rod clockwise (CW) to decrease maximum pump delivery or counter-clockwise (CCW) to increase maximum pump delivery until desired setting is obtained. Secure this setting by tightening locknut.

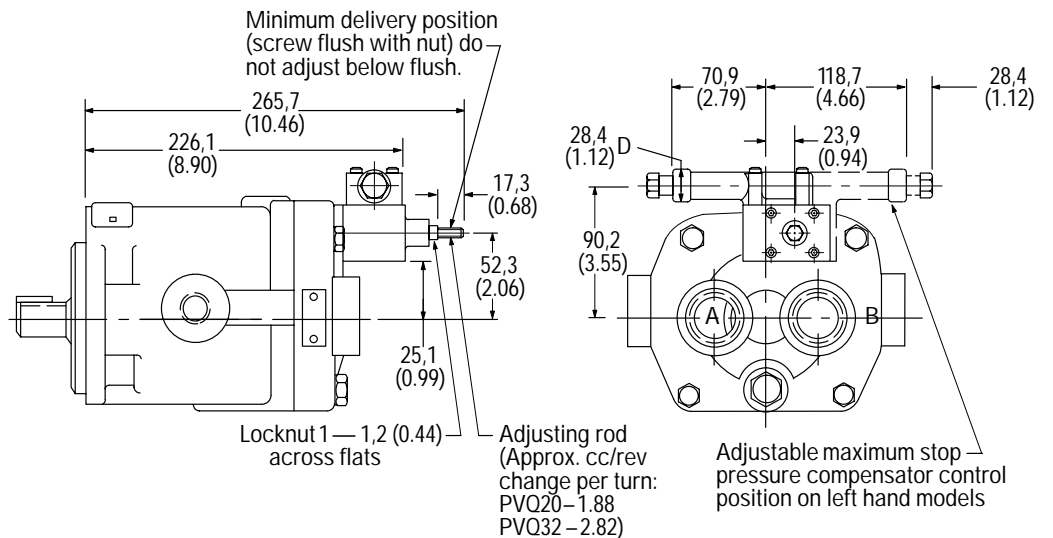

Electric Dual Range Pressure Compensator Control

Adjustment

1. With the directional valve de-energized, loosen locknut "5" and turn the adjusting screw "4" to the desired first stage pressure setting, then tighten locknut "5".
2. With solenoid de-energized, turn adjusting spool "1" counterclockwise (CCW) until nut "3" is bottomed in adjusting screw slot. (Second stage setting is now equal to first stage pressure setting.) Turn adjusting spool clockwise (CW) to desired second stage pressure requirements. One complete turn of adjusting spool equals approximately 41 bar (600 psi). Energize solenoid and check pressure setting. De-energize solenoid and re-adjust if necessary. Secure this setting by tightening locknut "2".

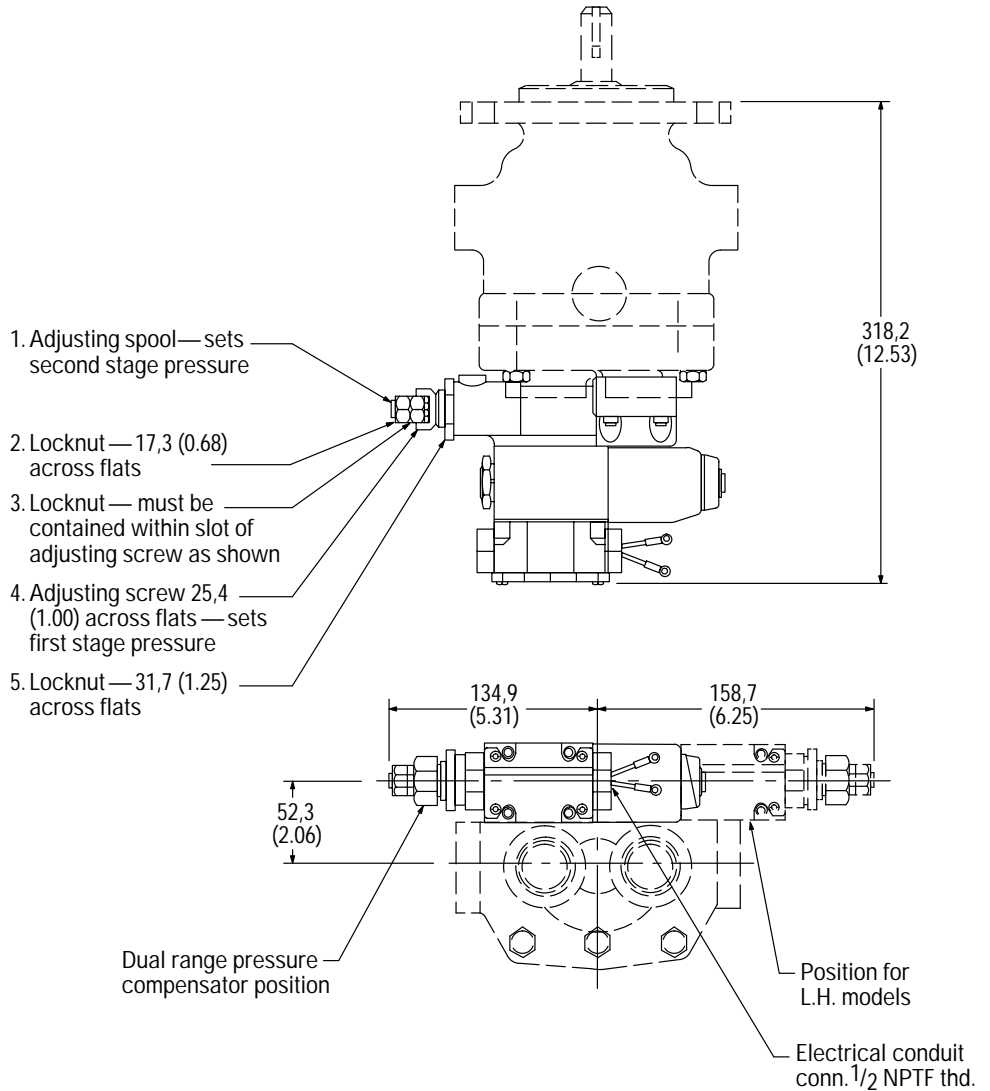

Solenoid Data (110V AC 50 Hz and 115/120V AC 60 Hz)

Solenoid current	Inrush amps (R.M.S.)	Holding amps
115/120V AC 60 Hz –	2.0	.54
110V AC 50 Hz		.64*

*Maximum peak inrush amps approximately 1.4 x R.M.S. value shown.

Refer to catalog GB-C-2015B for additional solenoid valve data.

Controls

Electric Dual Range Pressure Compensator with Maximum Displacement Stop

Maximum Flow Adjustment

With the system pressure below both compensator settings, loosen maximum stop adjusting screw locknut and adjust screw to desired flow position (turning screw clockwise decreases flow and turning screw counterclockwise increases flow). To lock screw in position, tighten locknut. To assist initial priming, adjust control setting to at least 40% of maximum flow position.

Compensator Control

1. With the directional valve de-energized, loosen locknut "5" and turn the adjusting screw "4" to the desired first stage pressure setting, then tighten locknut "5".
2. With directional valve de-energized, turn adjusting spool "1" counterclockwise until nut "3" is bottomed in adjusting screw slot. (Second stage setting is now equal to first stage pressure setting.) Turn adjusting spool clockwise to desired second stage pressure requirements. One complete turn of adjusting spool equals approximately 41 bar (600 psi). Energize solenoid and check pressure setting. De-energize solenoid and re-adjust if necessary. Secure this setting by tightening locknut "2".

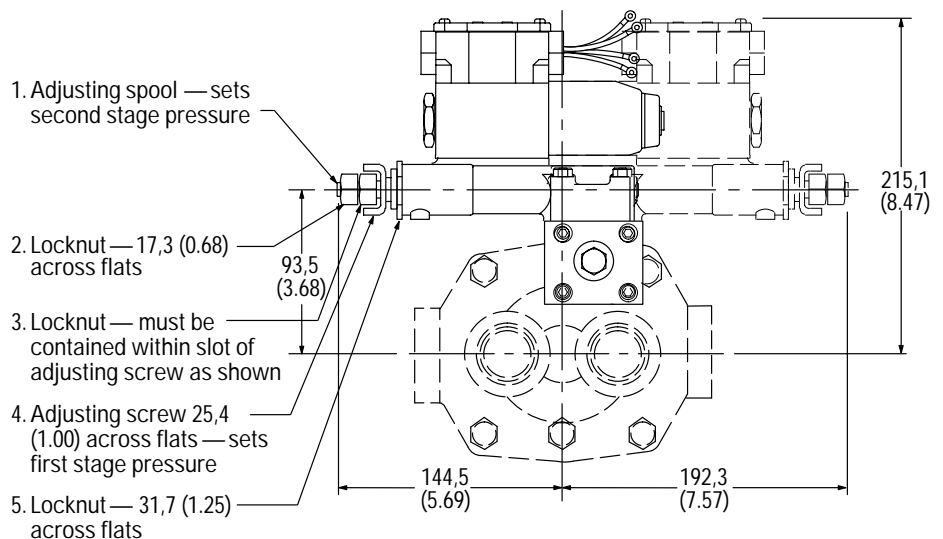
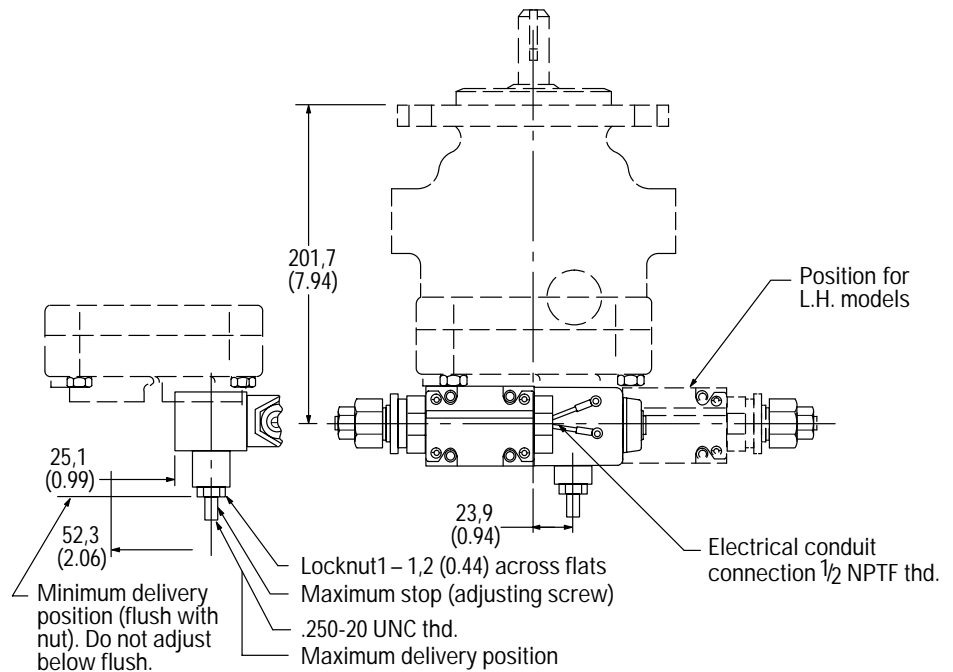

Controls

Unloading Valve Control

With the unloading valve control the variable pump will unload at a preset pressure. The pump will maintain this no flow, low pressure (approximately 14 bar [200 psi]) standby condition, until system pressure drops to about 85% of the preset unloading pressure. The pump will then return on stroke and provide full flow until the preset unloading pressure is reached again.

With this control, an efficient accumulator charging circuit is obtained. The pump will provide full flow to fill the accumulator until the maximum charging pressure is reached. The pump then goes to a standby condition until the accumulator pressure drops to 85% of the desired maximum. The accumulator is then recharged as the cycle starts over again.

A separate right angle check valve must be provided to maintain the accumulator hydraulic charge and prevent back flow when the pump is unloaded. The check valve's internal leakage must not exceed five drops per minute. The control port must be connected to system pressure, downstream of the check valve.

Adjustment range

PVQ20	100-210 bar (1500-3000 psi)
PVQ32	100-140 bar (1500-2000 psi)

Cut-in pressure is 85% of unloading pressure, minimum.

Setting Pressures

1. Back out accumulator unloading pressure adjustment screw to below desired unloading pressure.
2. Adjust desired standby pressure.
3. Set accumulator pressure by screwing in the accumulator unloading adjustment screw. Accumulator recharge (cut-in) pressure is a function of the maximum accumulator pressure and is not adjustable.
4. Check pressure settings and re-adjust if necessary.

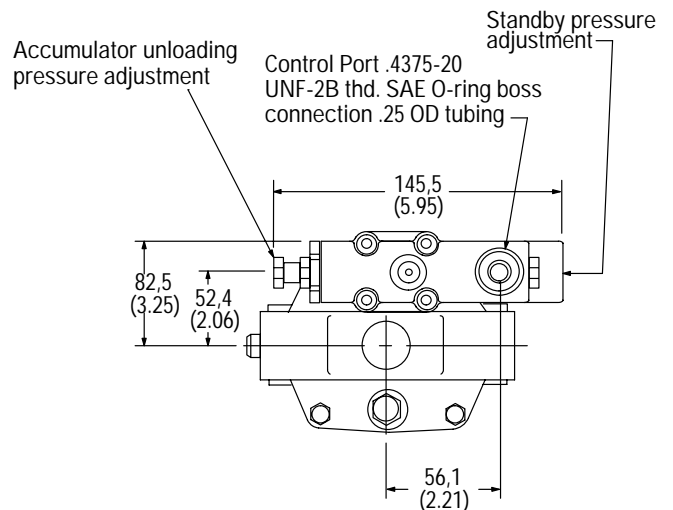
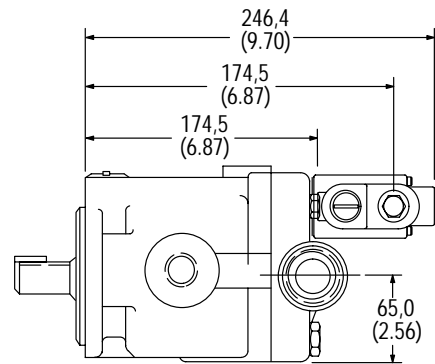
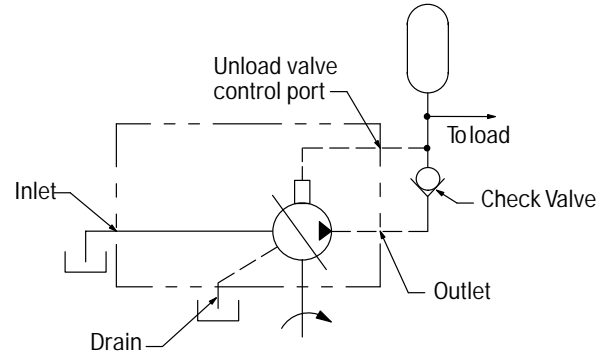

Thru-drives
 PVQ20/32
 "A9" and "A11"
 SAE "A"

No. 1 shaft. Input torque not to exceed 73 Nm (650 lb. in.) plus tabulated auxiliary pump torque with no overhung load. Applications requiring overhung load capability or other shaft ends are subject to approval by Vickers Engineering.

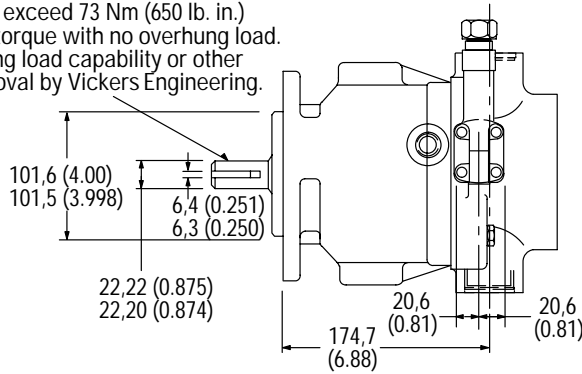

Note: Ports are reversed for L.H. rotation. Control location same for both L.H. and R.H. rotation.

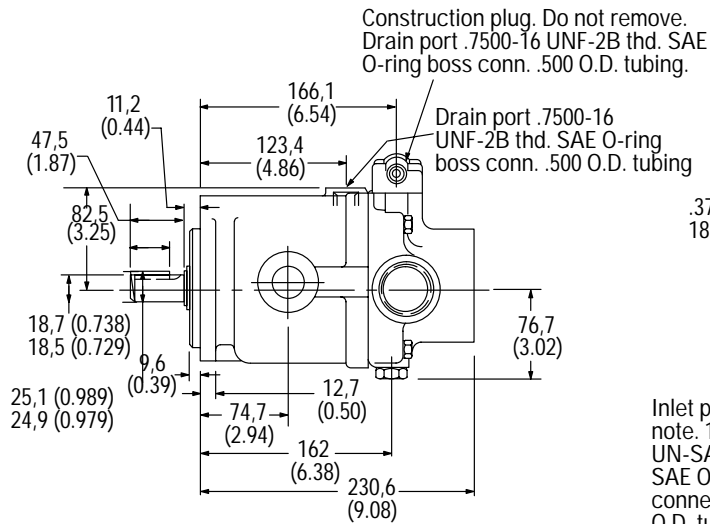

Caution: While pump is operating, do not back compensator adj. out beyond 28,4 (1.12) dim. shown.

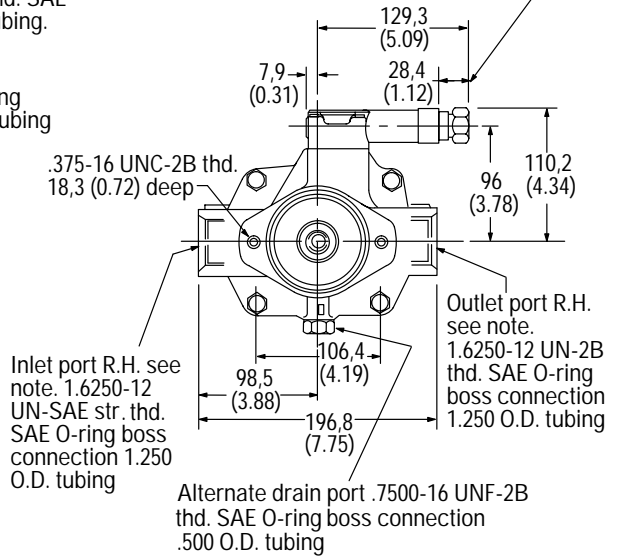

Thru-drives

PVQ20/32

"A9" and "A11"

SAE "A"

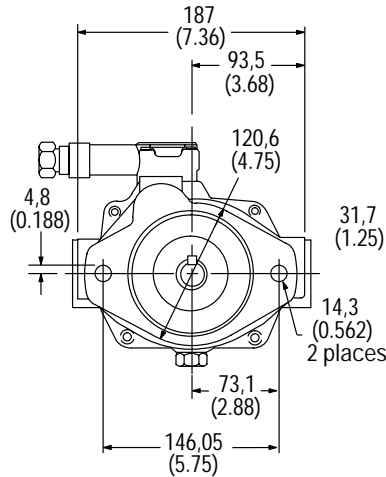

Note: Ports are reversed for L.H. rotation. Control location same for both L.H. and R.H. rotation.

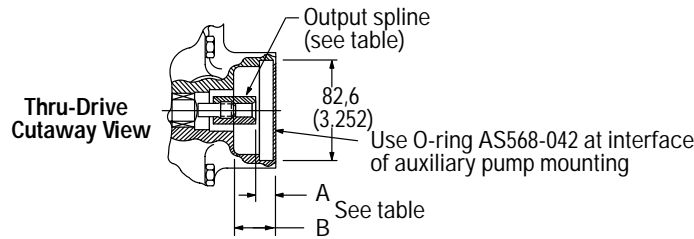

PVQ20/32 "A9" AND "A11" SAE "A"

Model Number System	Spline Data	Max. Torque Nm (in. lb.)	Installation Dimensions mm (in)		Coupling Kit
			A	B	
"A9"	ASA B5.15-1960 9 teeth 16/32 DP Flat root side fit	58 (517)	16,7 (0.66)	33,0 (1.30)	02-136810
"A11"	ANS B92.1-1970 11 teeth 16/32 DP Flat root side fit	123 (1100)	18,5 (0.73)	39,1 (1.54)	02-306041

Note: O-ring included with pump. Coupling kit, cap screws, and washers must be ordered separately to mount rear pump.

Typical Rear Pumps (with shaft codes) for PVQ20/32 Thru-drives

TYPICAL REAR PUMPS (WITH SHAFT CODES) FOR PVQ20/32 THRU-DRIVES

Model Series	Typical Rear Pump	Rear Pump Shaft Code	Thru-drive Coupling Kit
"A9"	PVQ10/13	3	02-136810
	PVB5/6	S124 suffix	
	V10	11	
	V20	62	

Note: "A11" (not listed above) is intended for special application only.

Model Number System

PVQ25

1	2	3	4	5	6	7	8	9	10	11	12	13	14	15	16	17	18	19	20	21	22	23	24	25	26	27	28	29	30	31
P	V	Q	2	5	A	R	1	1	A	A	1	0	B	1	1	2	4	0	0	A	2	0	0	1	A	P	C	9	0	1

Nos	Feature	Code	Description	Nos	Feature	Code	Description
1,2	Code title	PV	Open circuit piston pump	13	Diagnostic pressure point	0	No diagnostic pressure point
3,4,5,6	Displacement	Q25A	25.2cm ³ /r [1.54 in ³ /r]	14	Controller type	C	Electric dual range pressure Compensator with directional control valve
7	Input shaft rotation	L R	Left-hand rotation (CCW) Right-hand rotation (CW)			E	Unloading valve (accumulator circuits)
8,9	Front mounting and input shaft	01 05 09 10	2 Bolt B (SAE J744-101-2) with 22.2 [.88] DIA straight keyed shaft (SAE J744-22-1), key included 2 Bolt B (SAE J744-101-2) with 13T 16/32DP 41.1 [1.62] long splined shaft 2 Bolt B (SAE J744-101-2) with 26T 32/64DP splined shaft Shaft-2 Bolt VDMA A with 25.0 [.984] DIA straight keyed shaft, key included			G	Adjustable pressure compensator
				15,16	Pressure comp./ unloading valve setting	H J	Adjustable pressure and flow compensator Adjustable hydraulic remote control pressure compensator
10,11	Main ports location and size	AU AV	End ports; tube ports per SAE J514, suction 1.625-12 UN-2B, pressure – 1.0625-12 UN-2B SAE End ports; tube ports per ISO 6149-1, suction M42 x 2, pressure – M27 x 2	17,18	Flow comp. setting or unload VLV standby	07 33	65.5-72.4 bar [950-1050 lbf/in ²] 206.8-213.7 bar [3000-3100 lbf/in ²]
				19,20	Secondary compensator setting	00 04	No flow compensator setting 186.2-193.1 bar [2700-2800 lbf/in ²]
12	Drain port size	6 7 8 B C D	M18 metric O-ring port – top (D1) M18 metric O-ring port – bottom (D2) M18 metric O-ring port – shaft up .750-16 UNF-2B SAE O-ring port – top (D1) .750-16 UNF-2B SAE O-ring port – bottom (D2) .750-16 UNF-2B SAE O-ring port – shaft up	21	Control special features	0 A B	No special features Bleed down orifice – External manual stroke adjustment
				22	Maximum displacement option	1 2	Standard displacement Adjustable maximum displacement (set at maximum)

Note: Consult an Eaton representative for additional settings

Model Number System PVQ25

1	2	3	4	5	6	7	8	9	10	11	12	13	14	15	16	17	18	19	20	21	22	23	24	25	26	27	28	29	30	31
P	V	Q	2	5	A	R	1	1	A	A	1	0	B	1	1	2	4	0	0	A	2	0	0	1	A	P	C	9	0	1

Nos	Feature	Code	Description
23,24	Auxiliary mounting and output shaft	00	No auxiliary mounting or output shaft
25	Shaft seals	0	No shaft seal
		1	Standard shaft seal (nitrile) Vitron option
		3	Fluorocarbon
		4	HNBR shaft seal luster glycol fluids
26,27	Special features	AP	Cast iron housing and industrial timing
28,29	Paint	00	No paint
		CD	Blue primer
30	Customer and unit identification	0	STD – mark assembly Number and build data Code on plate
31	Design code	A	First

Note: Consult an Eaton representative for additional settings

RATINGS

Model Number System	Maximum Geometric Displacement cm ³ /r (in ³ /r)	Rated Speed r/min	Maximum Pressure bar (psi)	Input Power at Max. Pressure and Rated Speed kW (hp)	Approx. Weight kg (lb)
PVQ25	25,2 (1.54)	1800	210 (3000)	16 (24)	14 (31)

Pressure Limits:

Case pressure – 0,35 bar (5 psig) maximum
Inlet pressure – 0,2 bar (5 in. Hg) vacuum to 2 bar (30 psig)

Controls

“G” Option

Pressure Compensator Controls

The pressure compensator control automatically adjusts pump delivery to maintain volume requirements of the system at a preselected operating pressure. Maximum pump delivery is maintained to approximately 75 psi (PVQ025) below the pressure setting before being reduced. The pressure compensator control operates on one side of center and has an adjustment range as designated in the model numbering system.

Pressure Compensator Control with Adjustable Maximum Displacement Stop

The adjustable maximum stop pressure control enables the maximum pump delivery to be externally adjusted from 25% to 100% while maintaining all of the standard features of a pressure compensated pump. To assist initial priming, manual adjustment control setting must be at least 40% of maximum flow position.

“J” Option

Remote Control Pressure Compensator

Exactly the same as the pressure compensation option, except the machine operator is able to change the compensator setting through the use of a remote pilot relief valve, such as Eaton C-175.

“C” Option

Electric Dual Range Pressure Compensator Control

The dual range pressure compensator control automatically adjusts pump delivery to maintain volume requirements of the system at either of two preselected operating pressures.

Maximum pump delivery is maintained to approximately 75 psi (PVQ025) below either pressure control setting before being reduced.

Control type and pressure range are designated in the model number system.

Note: Graphic symbols shown with external valve(s) and cylinder to illustrate typical usage.

“H” Option

Load Sensing and Pressure Limiter Compensator Control

This compensator provides load-sensing control under all pressure conditions up to the desired maximum. It automatically adjusts pump flow in response to a remote pressure signal and maintains outlet pressure at a level slightly above load pressure. The integral pressure limiter overrides the load-sensing control, reducing pump displacement as the preset maximum operating pressure is reached.

Standard load-sense differential pressure settings, by control type, follow. See model number system for setting range.

Standard load-sensing and pressure limiting control with 11 bar differential pressure (standard factory setting). Includes bleed-down orifice to exhaust load-sense signal for low-pressure standby condition.

Other Standard Load Sense Options:

1. Bleed-down orifice plugged.
2. Factory differential pressure setting of 24 bar.

“G” Option

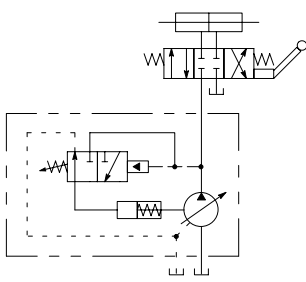

“J” Option

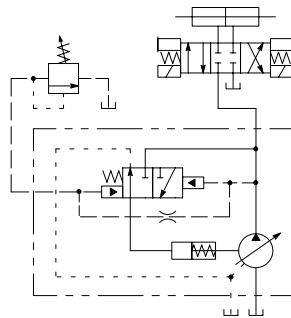

“H” Option

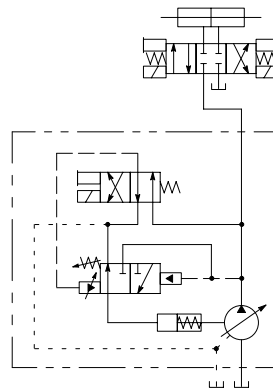

“C” Option

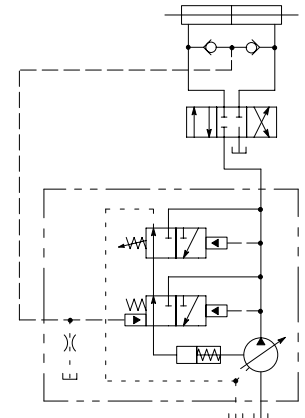

(torifice open)
(torifice plugged)

PVQ25 Performance Curves

Performance at 1800 r/min
 Oil type: SAE 10W
 Oil temp: 50° C (120° F)
 Inlet pressure: 0 psi

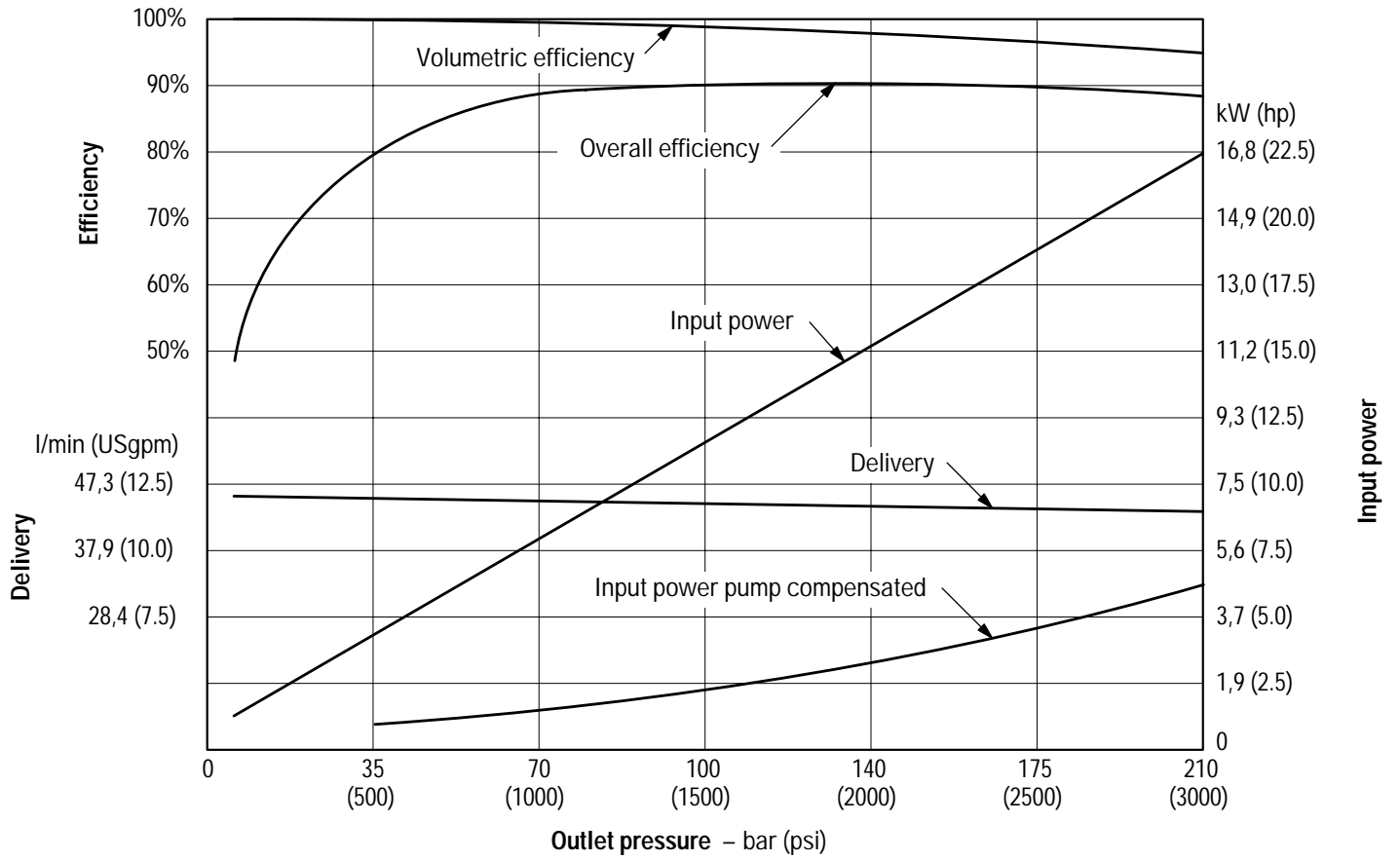

PVQ25

Operating Data

Sound Data

Temperature: 50°C (120°F)
 Test Fluid: URSA-ED (10W)
 Inlet Pressure: Atmospheric
 (0 psig)

SOUND DATA

Speed r/min	Pressure bar (psi)	Sound Level dB(A)*	
		Full Stroke	Cutoff
1000	35 (500)	56.5	54.9
	70 (1000)	57.7	58.3
	100 (1500)	58.6	60.0
	140 (2000)	59.5	61.3
	175 (2500)	60.9	62.0
	210 (3000)	66.6	63.1
1200	35 (500)	60.9	56.9
	70 (1000)	62.4	60.1
	100 (1500)	63.1	62.3
	140 (2000)	63.3	63.6
	175 (2500)	63.8	64.5
	210 (3000)	63.8	65.5
1500	35 (500)	61.9	57.7
	70 (1000)	63.5	61.9
	100 (1500)	64.2	62.7
	140 (2000)	65.3	63.3
	175 (2500)	65.1	64.7
	210 (3000)	65.9	65.3
1800	35 (500)	64.0	59.0
	70 (1000)	65.2	62.0
	100 (1500)	66.0	63.4
	140 (2000)	67.1	64.4
	175 (2500)	67.5	65.7
	210 (3000)	67.4	66.6

*Sound pressure data equivalent to NFPA Standard.

Response Data

Yoke response recorded at rated speed and pressure, 0 psi inlet, 82°C (180°F), SAE 10W oil. Pressure rise was 6900 bar (100,000 psi) per second.

Control Type	On stroke	Off stroke
Pressure compensator	0.030 sec.	0.012 sec.
Load sense compensator	0.040 sec.	0.012 sec.

Installation Drawings

PVQ25 with Pressure Compensator Control

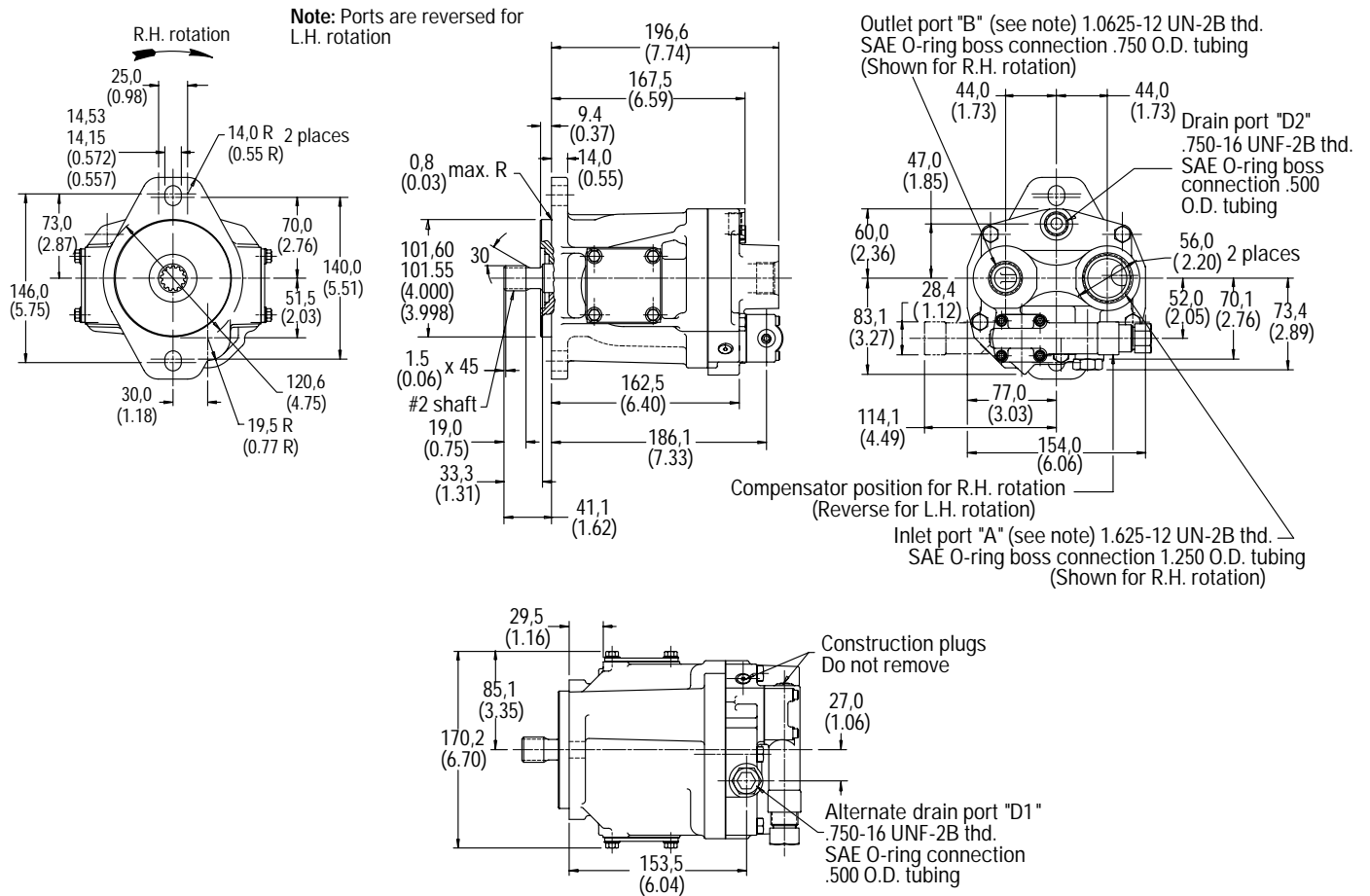

Shaft Options

No. 1 Shaft

SAE "B" Straight keyed

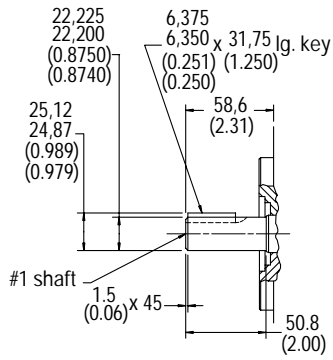

No. 10 Mounting and Input Shaft

(Flange and shaft end ISO 3019/21000A2HW-E25N)

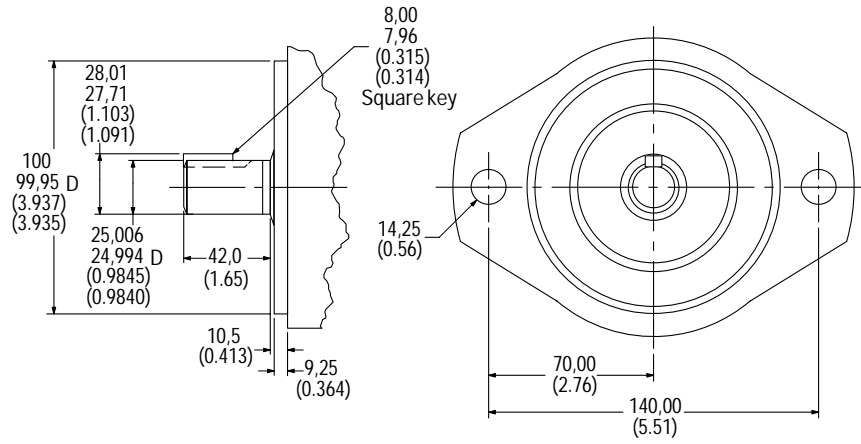

Load Sensing with Pressure Limiter

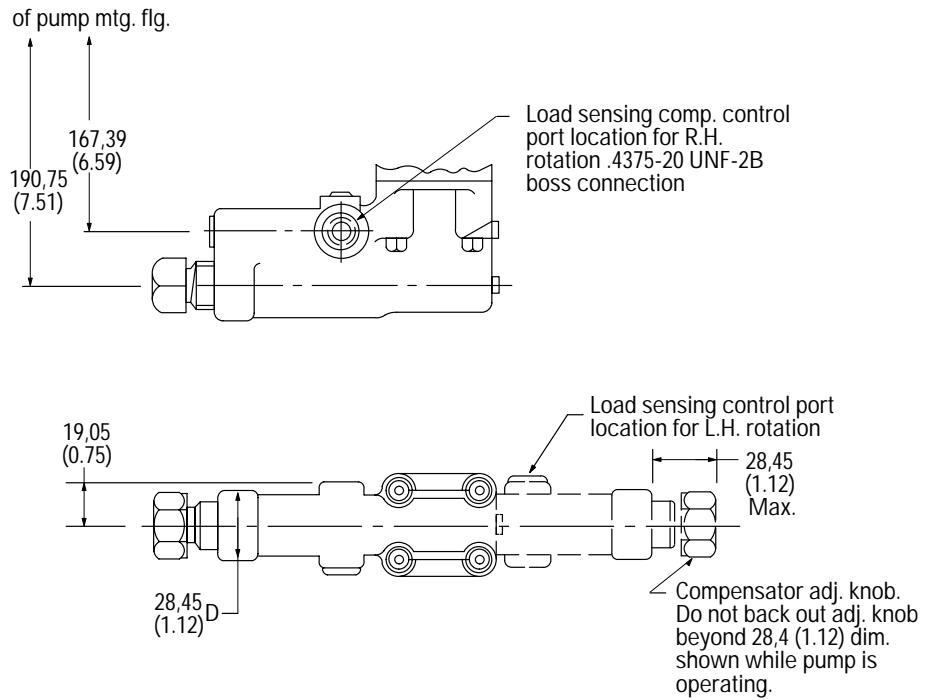

Remote Compensator

Adjustment

1. Turn pressure control (such as C-175) CCW to minimum setting.
2. Turn compensator adjustment plug to desired minimum pressure (17 bar, 250 psi or higher).
3. Full pressure range can now be obtained with pressure control.

Caution: Effective compensator pressure will be compensator control setting (17-69 bar, 250-1000 psig) plus remote relief valve setting.

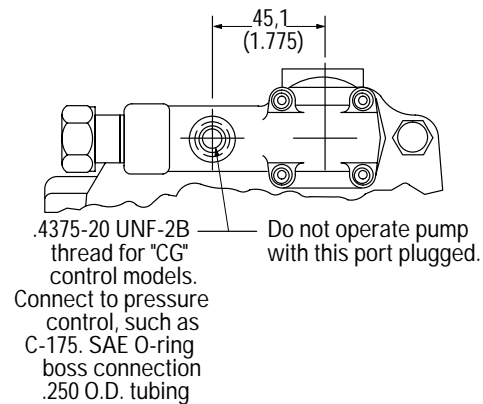

Pressure Compensator Control with Adjustable Max. Displacement Stop

Adjustment

Loosen locknut on adjusting rod. Turn adjusting rod clockwise (CW) to decrease maximum pump delivery or counterclockwise (CCW) to increase maximum pump delivery until desired setting is obtained. Secure this setting by tightening locknut.

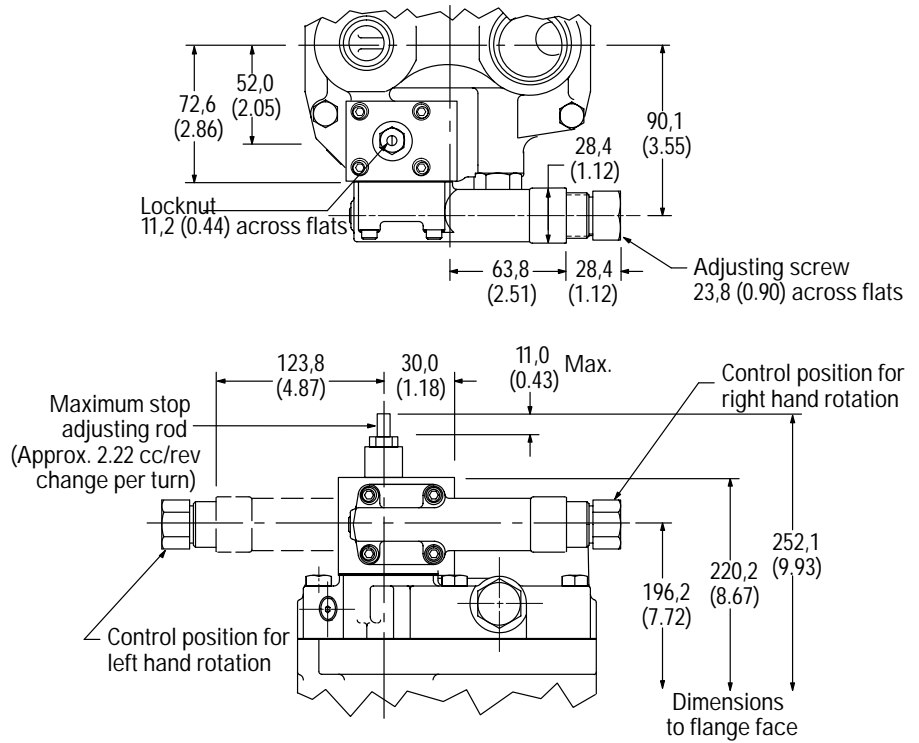

Controls

Electric Dual Range Pressure Compensator Control

Adjustment

1. With the directional valve de-energized, loosen locknut "5" and turn the adjusting screw "4" to the desired first stage pressure setting, then tighten locknut "5".
2. With solenoid de-energized, turn adjusting spool "1" counterclockwise (CCW) until nut "3" is bottomed in adjusting screw slot. (Second stage setting is now equal to first stage pressure setting.) Turn adjusting spool clockwise (CW) to desired second stage pressure requirements. One complete turn of adjusting spool equals approximately 41 bar (600 psi). Energize solenoid and check pressure setting. De-energize solenoid and re-adjust if necessary. Secure this setting by tightening locknut "2".

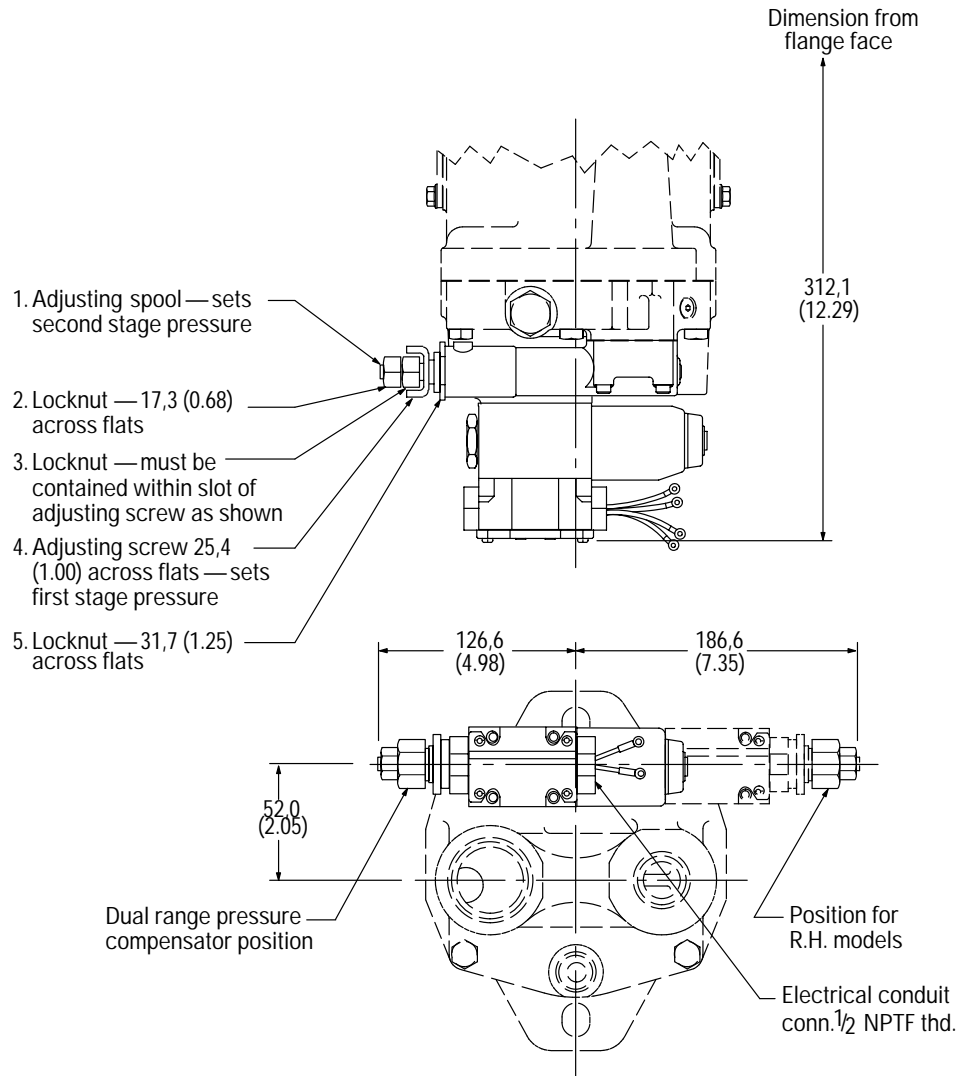

Solenoid Data (110V AC 50 Hz and 115/120V AC 60 Hz)

Solenoid current	Inrush amps (R.M.S.)	Holding amps
115/120V AC 60 Hz –	2.0	.54
110V AC 50 Hz		.64*

*Maximum peak inrush amps approximately 1.4 x R.M.S. value shown.
Refer to catalog GB-C-2015B for additional solenoid valve data.

Controls Electric Dual Range Pressure Compensator with Maximum Displacement Stop

Maximum Flow Adjustment

With the system pressure below both compensator settings, loosen maximum stop adjusting screw locknut and adjust screw to desired flow position (turning screw clockwise decreases flow and turning screw counterclockwise increases flow). To lock screw in position, tighten locknut. To assist initial priming, adjust control setting to at least 40% of maximum flow position.

Compensator Control

1. With the directional valve de-energized, loosen locknut "5" and turn the adjusting screw "4" to the desired first stage pressure setting, then tighten locknut "5".
2. With directional valve de-energized, turn adjusting spool "1" counterclockwise until nut "3" is bottomed in adjusting screw slot. (Second stage setting is now equal to first stage pressure setting.) Turn adjusting spool clockwise to desired second stage pressure requirements. One complete turn of adjusting spool equals approximately 41 bar (600 psi). Energize solenoid and check pressure setting. De-energize solenoid and re-adjust if necessary. Secure this setting by tightening locknut "2".

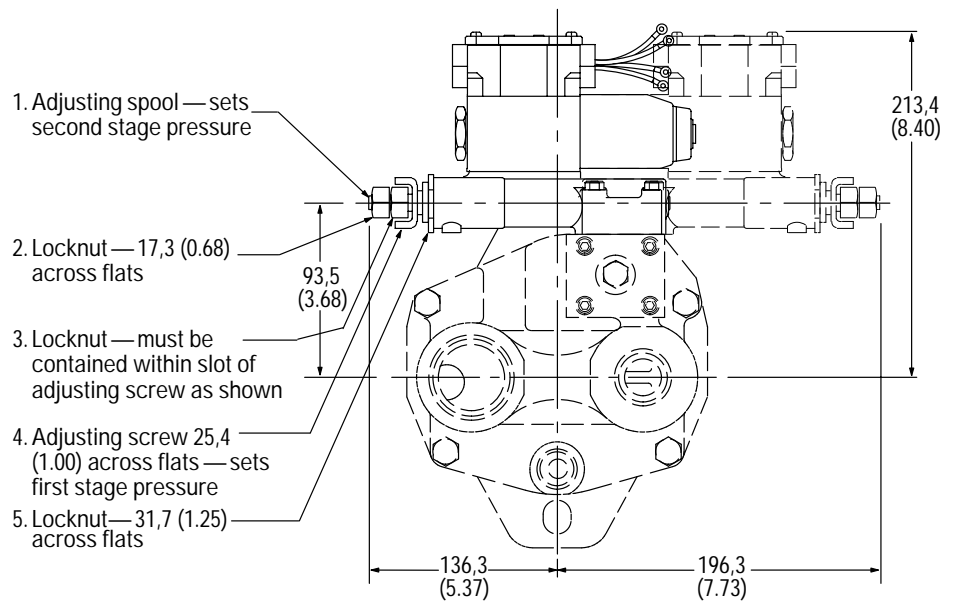
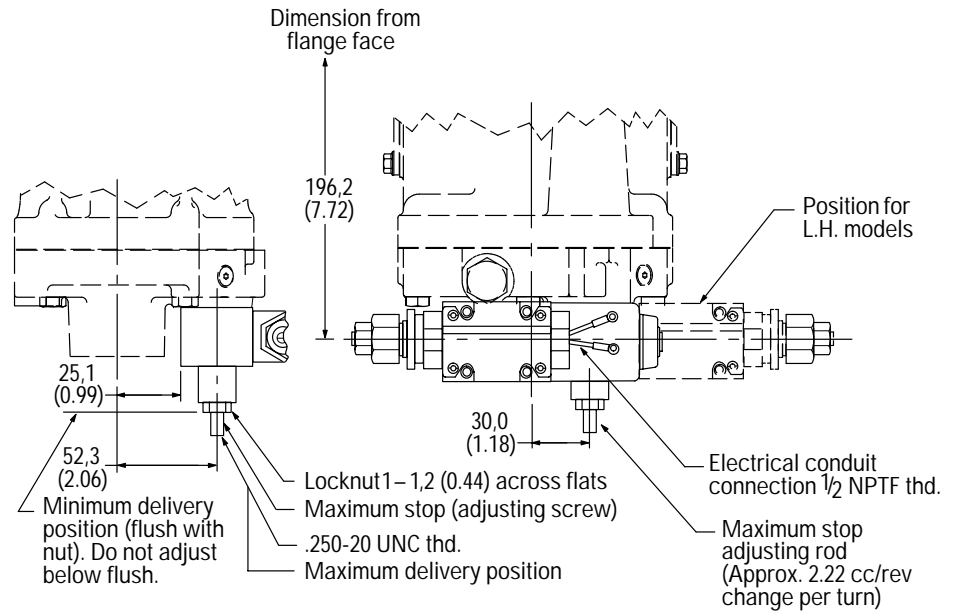

Controls

Unloading Valve Control – “E” Option

With the unloading valve control the variable pump will unload at a preset pressure. The pump will maintain this no flow, low pressure (approximately 14 bar [200 psi]) standby condition, until system pressure drops to about 85% of the preset unloading pressure. The pump will then return on stroke and provide full flow until the preset unloading pressure is reached again.

With this control, an efficient accumulator charging circuit is obtained. The pump will provide full flow to fill the accumulator until the maximum charging pressure is reached. The pump then goes to a standby condition until the accumulator pressure drops to 85% of the desired maximum. The accumulator is then recharged as the cycle starts over again.

A separate right angle check valve must be provided to maintain the accumulator hydraulic charge and prevent back flow when the pump is unloaded. The check valve's internal leakage must not exceed five drops per minute. The control port must be connected to system pressure, downstream of the check valve.

Adjustment range

PVQ25 100-210 bar (1500-3000 psi)

Cut-in pressure is 85% of unloading pressure, minimum.

Setting Pressures

1. Back out accumulator unloading pressure adjustment screw to below desired unloading pressure.
2. Adjust desired standby pressure.
3. Set accumulator pressure by screwing in the accumulator unloading adjustment screw. Accumulator recharge (cut-in) pressure is a function of the maximum accumulator pressure and is not adjustable.
4. Check pressure settings and re-adjust if necessary.

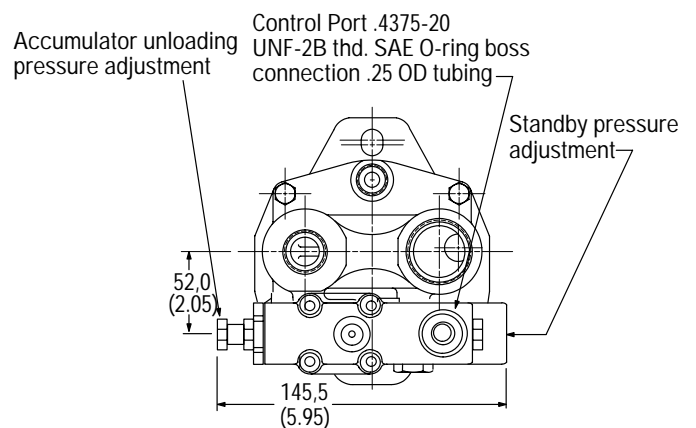
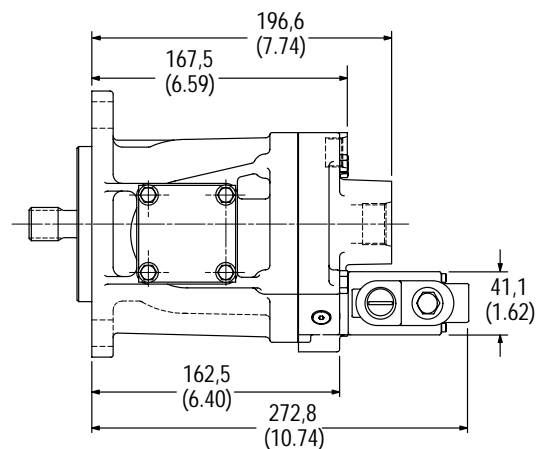
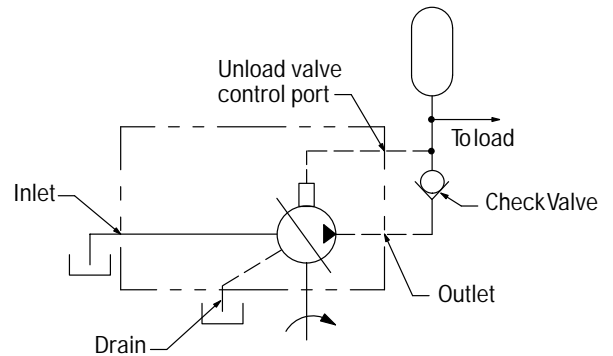

Model Number System PVQ40 and PVQ45

1 2 3 4 5 6 7 8 9 10 11 12 13 14 15 16 17 18 19 20 21 22 23 24 25 26 27 28 29 30 31																														
P V Q 4 0 A R 1 1 A A 1 0 B 1 1 2 4 0 0 A 1 A A 1 A F C D 0 1																														
Nos	Feature	Code Description	Nos	Feature	Code Description																									
1,2	Code title	PV Open circuit piston pump	12	Drain port size and location	1 .875-14 UNF-2B SAE O-ring port-top (D1) 2 .875-14 UNF-2B SAE O-ring port - bottom (D2) 3 .875-14 UNF-2B SAE O-ring port - shaft up 6 M18 X 1.5 metric O-ring port - top (D1) 7 M18 X 1.5 metric O-ring port - bottom (D2) 8 M18 X 1.5 metric O-ring port - shaft up																									
3,4,5,6	Displacement	Q40A 41.0cm ³ /r [2.50 in ³ /r] Q45A 45.1cm ³ /4 [2.75 in ³ /r]																												
7	Input shaft rotation	L Left-hand rotation (CCW) R Right-hand rotation (CW)																												
8,9	Front mounting and input shaft	01 2 Bolt B (SAE J744-101-2) with 22.2 [.88] DIA straight key shaft (SAE J744-22-1) (key included) 02 2 Bolt B-B (SAE J744-101-2) with 25.4 [1.00] DIA straight key shaft (SAE J744-25-1) (key included) 05 2 Bolt B-B (SAE J744-101-2) with 13T 16/32DP 41.1 [1.62] long splined shaft 08 2 Bolt B-B (SAE J744-101-2) with 15T 16/32DP splined shaft 09 2 Bolt B (SAE J744-101-2) with 26T 32/64DP splined shaft 10 Shaft-2 Bolt VDMA A with 25.0 [.984] DIA straight keyed shaft, key included	13	Diagnostic pressure port	0 No diagnostic pressure port 1 .4375-20 UNF-2B SAE O-ring port - plugged 2 M14 X 1.5 metric O-ring port - plugged																									
10,11	Main ports location and size	AA Side ports; tube ports per SAE J514, suction - 1.875-12 UN-2B, pressure - 1.3125-12 UN-2B AB End ports; tube ports per SAE J514, suction - 1.875-12 UN-2B, pressure - 1.3125-12 UN-2B AC Side ports; SAE J518 flange, suction - 1.500 SAE 4-bolt split flange port (code 61); pressure - 1.000 SAE 4-bolt split flange port (code 61) AD End ports; SAE J518 flange, suction - 1.500 SAE 4-bolt split flange port (code 61); pressure - 1.000 SAE 4-bolt split flange port (code 61) AE Side ports; ISO 6149-1 tube, suction - M48 X 2, pressure - M33 X 2 AF End ports; ISO 6149-1 tube, suction - M48 X 2, pressure - M33 X 2 AS End ports; ISO 6162 flange, suction - 1.500 SAE 4-bolt split flange port with M12 X 1.75 threads; pressure - 1.000 SAE 4-bolt split flange port with M10 X 1.5 threads	15,16	Pressure comp./ unloading valve	07 65.5-72.4 bar [950-1050 lbf/in ²] 18 182.7-189.6 bar [2650-2750 lbf/in ²] 33 206.8-213.7 bar [3000-3100 lbf/in ²]																									
			17,18	Flow comp. setting or unload valve standby	00 No flow compensator setting 11 9.65-12.41 bar [140-180 lbf/in ²] 14 12.41-15.17 bar [180-220 lbf/in ²] 24 22.75-25.51 bar [330-370 lbf/in ²]																									
			19,20	Secondary comp. setting	00 No secondary compensator setting 04 186.2-193.1 bar [2700-2800 lbf/in ²]																									
			21	Control special features	0 No special features A Bleed down orifice B External manual stroke adjustment																									
			22	Maximum displacement option	1 Standard displacement 2 Adjustable maximum displacement (set at maximum)																									

Note: Consult an Eaton representative for additional settings

Model Number System PVQ40 and PVQ45

1	2	3	4	5	6	7	8	9	10	11	12	13	14	15	16	17	18	19	20	21	22	23	24	25	26	27	28	29	30	31
P	V	Q	4	0	A	R	1	1	A	A	1	0	B	1	1	2	4	0	0	A	1	A	A	1	A	F	C	D	0	1

Nos	Feature	Code	Description				
23,24	Auxiliary mounting output shaft	00	No auxiliary mounting or output shaft	25	Shaft seals	0	No shaft seal
		AA	2 Bolt A (SAE J744-82-2) w/ 9T 16/32DP external splined shaft			1	Standard shaft seal (fluorocarbon)
		AB	2 Bolt A (SAE J744-82-2) w/ 11T 16/32DP external splined shaft	26,27	Special features	AP	Cast iron housing and industrial timing
		AC	2 Bolt B (SAE J744-101-2) w/ 13T 16/32 DP internal splined coupling	28,29	Paint	00	No paint
		AD	2 Bolt B (SAE J744-101-2) w/ 15T 16/32DP internal splined coupling			CD	Blue primer
		AE	2 Bolt B (SAE J744-101-2) w/ 26T 32/64DP external splined shaft	30	Customer and unit	0	STD – mark assembly number, full model code and build date code on plate
		AH	2 Bolt A (SAE J744-82-2) w/ 9T 16/32DP internal splined coupling	31	Design code	A	First design
		AJ	2 Bolt A (SAE J744-82-2) w/ 11T 16/32DP internal splined coupling				
		AK	2 Bolt B (SAE J744-101-2) w/ 26T 32/64DP internal splined coupling				

Note: Consult an Eaton representative for additional settings

RATINGS

Model Number System	Maximum Geometric Displacement cm ³ /r (in ³ /r)	Rated Speed r/min	Maximum Pressure bar (psi)	Input Power at Max. Pressure and Rated Speed kW (hp)	Approx. Weight kg (lb)
PVQ40	41,5 (2.500)	1800	210 (3000)	27,6 (37)	20,6 (45.4)
PVQ45	45,1 (2.750)	1800	186 (2700)	28,3 (38)	20,6 (45.4)

Pressure Limits:

Inlet pressure – 0,2 bar (5 in. Hg) vacuum to 2 bar (30 psig)
Case pressure – 0,35 bar (5 in. Hg) maximum

Note: Integral relief valve limits case pressure peaks to 0,7 bar (10 psi) higher than inlet pressure to protect pump. Flow from valve is returned directly to pump inlet. Use of case drain line required to limit steady-state case pressure.

Controls

"G" Option

Pressure Compensator Controls

This control automatically varies pump displacement to meet the system flow demand for a constant system pressure. Displacement starts to reduce to zero within 14 bar (200 psi) of the compensator setting. Power draw-off is minimized, therefore, system relief valves should not be required.

Pressure Compensator Control with Adjustable Maximum Displacement Stop

The adjustable maximum stop pressure control enables the maximum pump delivery to be externally adjusted from 25% to 100% while maintaining all of the standard features of a pressure compensated pump. To assist initial priming, manual adjustment control setting must be at least 40% of maximum flow position.

"J" Option

Remote Control Pressure Compensator

Exactly the same as the "C" (pressure compensation option) except the machine operator is able to change the compensator setting through the use of a remote pilot relief valve.

"C" Option

Electric Dual Range Pressure Compensator Control

The dual range pressure compensator control automatically adjusts pump delivery to maintain volume requirements of the system at either of two preselected operating pressures.

Maximum pump delivery is maintained to approximately 3,4 bar (50 psi) below either pressure control setting before being reduced.

Control type and pressure range are designated in the model number system.

Note: Graphic symbols shown with external valve(s) and cylinder to illustrate typical usage.

"H" Option

Load Sensing and Pressure Limiter Compensator Control

This compensator provides load-sensing control under all pressure conditions up to the desired maximum. It automatically adjusts pump flow in response to a remote pressure signal and maintains outlet pressure at a level slightly above load pressure. The integral pressure limiter overrides the load-sensing control, reducing pump displacement as the preset maximum operating pressure is reached.

Standard load-sense differential pressure settings, by control type, follow. See model number system for setting range.

Standard load-sensing and pressure limiting control with 11 bar differential pressure (standard factory setting). Includes bleed-down orifice to exhaust load-sense signal for low-pressure standby condition.

Other Standard Load Sense Options:

1. Bleed-down orifice plugged.
2. Factory differential pressure setting of 24 bar.

"G" Option

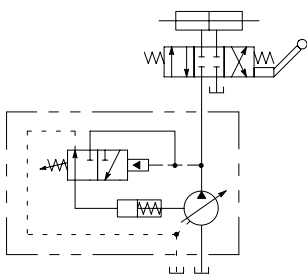

"J" Option

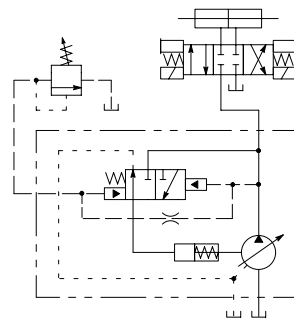

"C" Option

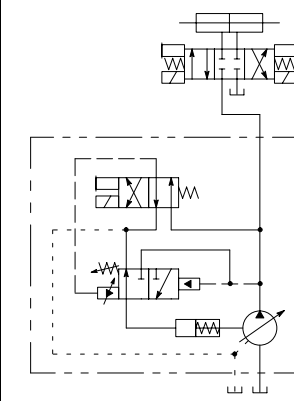

"H" Option

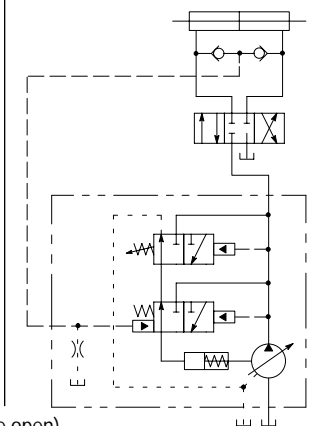

(*orifice open)
(*orifice plugged)

Performance Curves

PVQ40

Oil type: SAE 10W
 Oil temperature: 82°C (180°F)
 Inlet: 0 psi

Note: To obtain full flow operation of pump, pressure compensator setting must be 14 bar (200 psi) above desired operating pressure. Full flow curves were obtained with compensator settings 14 bar (200 psi) above 210 bar (3000 psi) max. rated pressure.

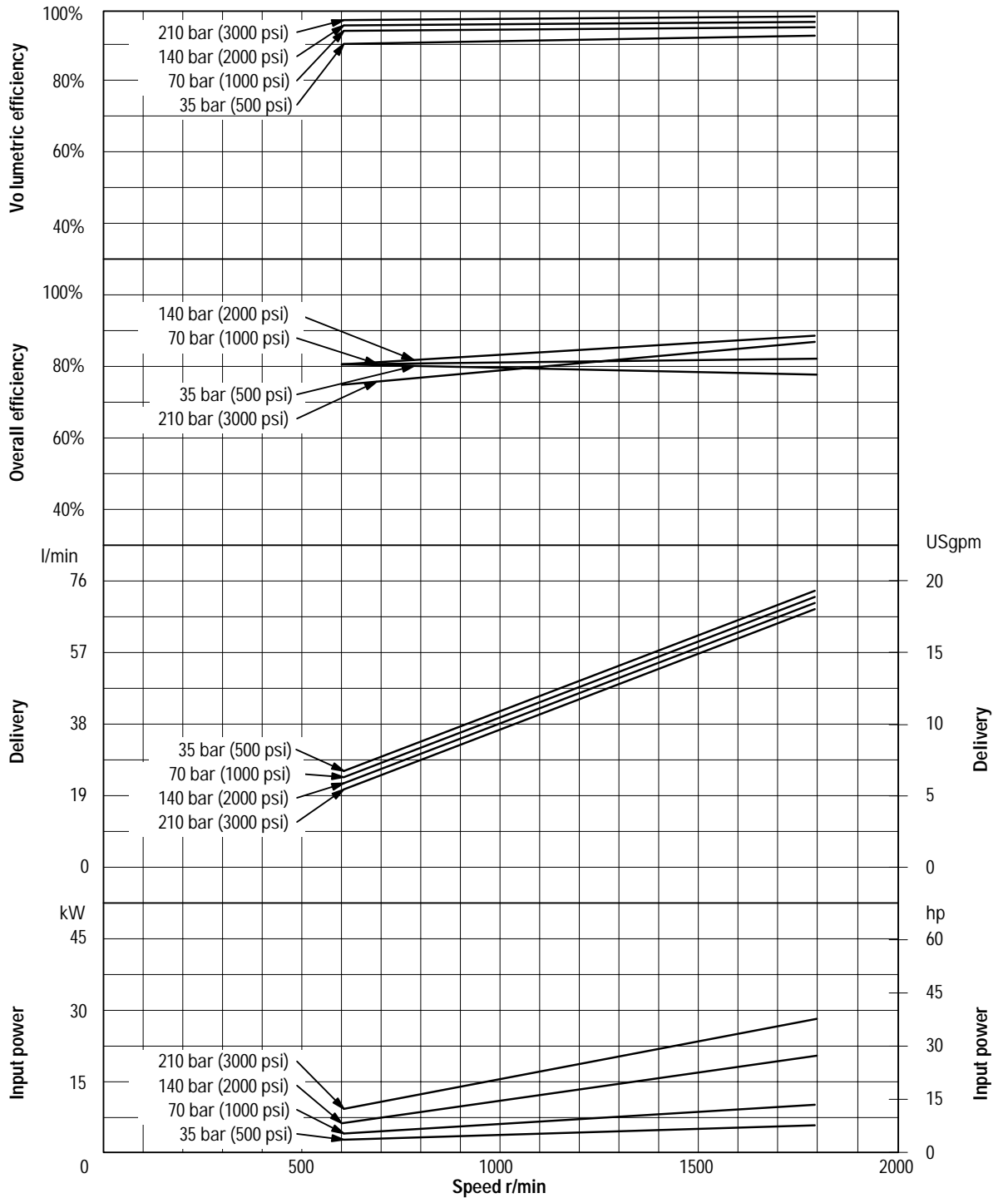

Model Series

PVQ45

Oil type: SAE 10W
 Oil temperature: 82°C (180°F)
 Inlet: 0 psi

Note: To obtain full flow operation of pump, pressure compensator setting must be 14 bar (200 psi) above desired operating pressure. Full flow curves were obtained with compensator settings 14 bar (200 psi) above 186 bar (2700 psi) max. rated pressure.

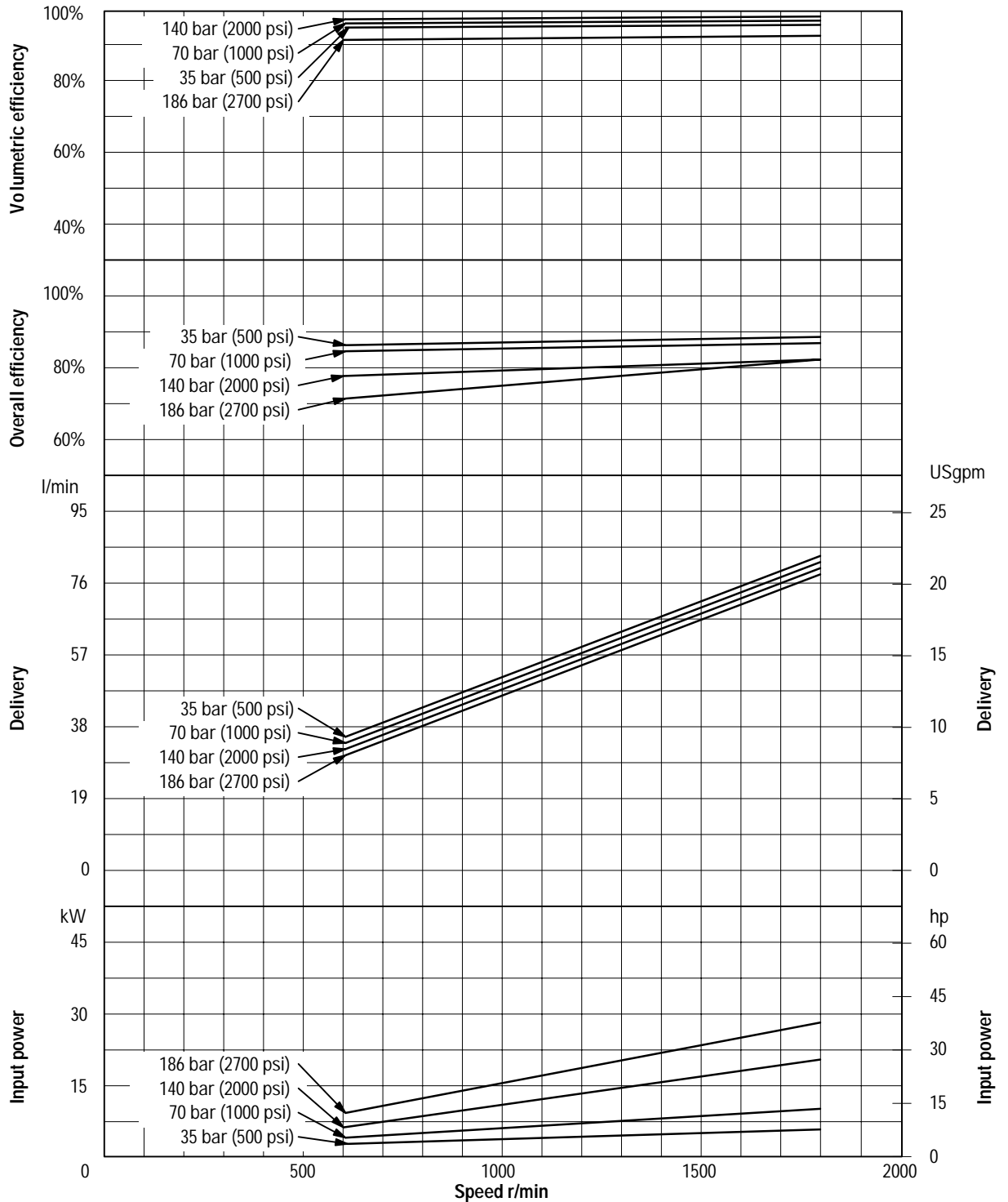

Operating Data

PVQ40 and PVQ45

Sound Data

Temperature: 50°C (120°F)
 Test Fluid: URSA-ED (10W)
 Inlet Pressure: Atmospheric
 (0 psig)

SOUND DATA

Speed r/min	Pressure bar (psi)	Sound Level dB(A)*	
		Full Stroke	Cutoff
1000	35 (500)	60	58
	70 (1000)	61	61
	140 (2000)	63	65
	210 (3000)*	65	65
1200	35 (500)	61	60
	70 (1000)	62	62
	140 (2000)	65	65
	210 (3000)*	66	68
1500	35 (500)	65	61
	70 (1000)	67	64
	140 (2000)	68	67
	210 (3000)*	68	69
1800	35 (500)	68	60
	70 (1000)	69	65
	140 (2000)	69	68
	210 (3000)*	71	70

*PVQ40 at 210 bar (3000 psi) and PVQ45 at 186 bar (2700 psi)

**Sound pressure data equivalent to NFPA Standard.

Response Data

Yoke response recorded at rated speed and pressure, 0 psi inlet, 82°C (180°F), SAE 10W oil. Pressure rise was 6900 bar (100,000 psi) per second.

Control Type	On Stroke	Off Stroke
Pressure compensator	0.050 sec.	0.020 sec.
Load sense compensator	0.040 sec.	0.010 sec.

Controls

Side Port Controls, No. 2 Mounting and Input Shaft

Millimeters (inches)

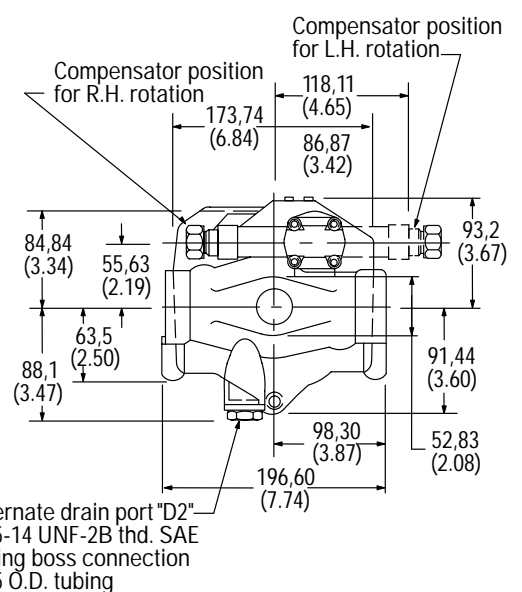
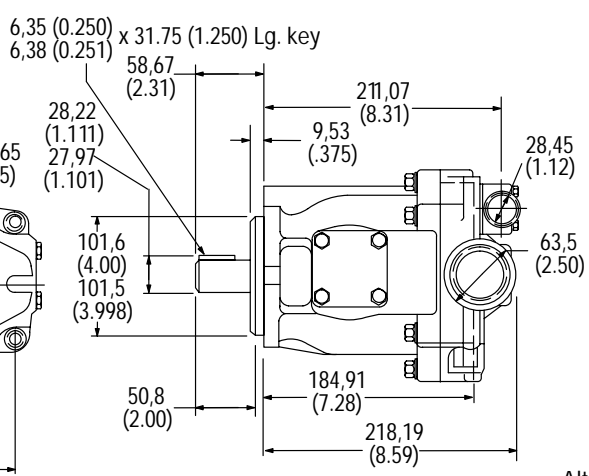
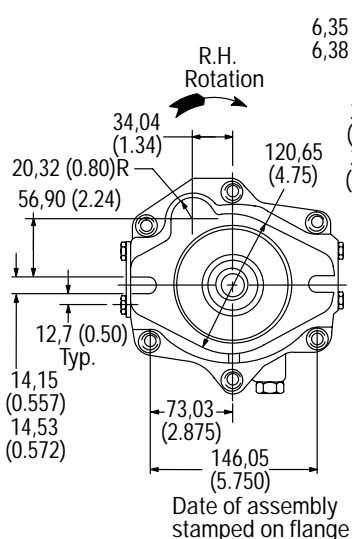
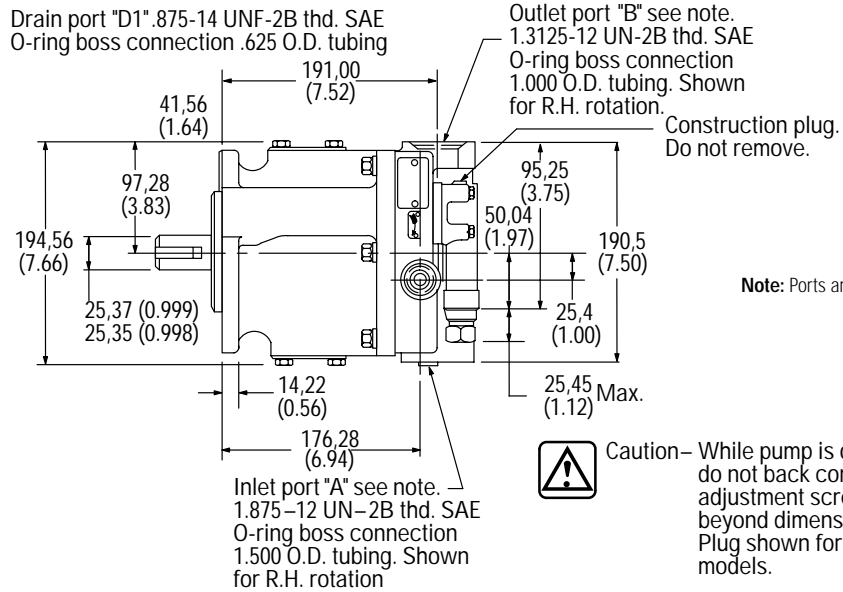

Rear Ports

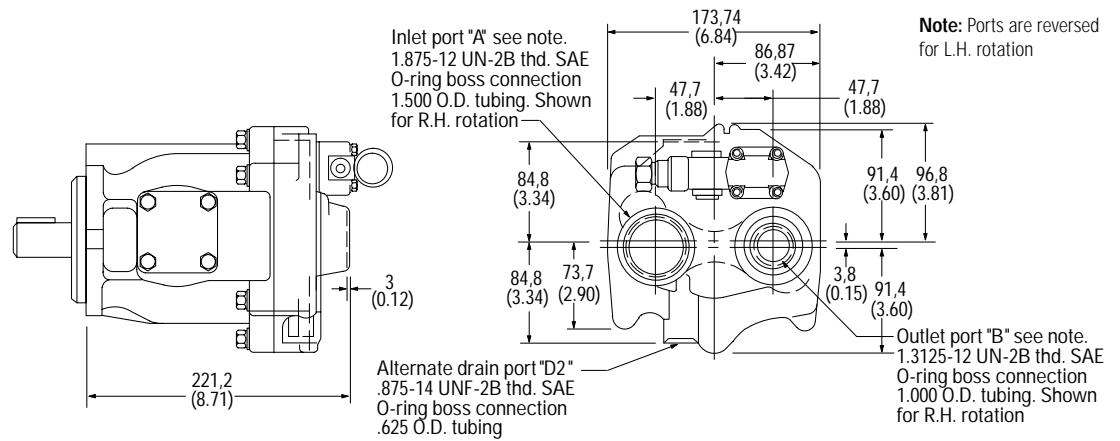

No. 1 Shaft: SAE "B" Straight Keyed

No. 05 Shaft
SAE "B" Splined

No. 08 Mounting
and Input Shaft
SAE "B-B" Splined

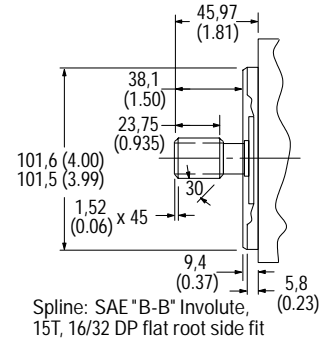
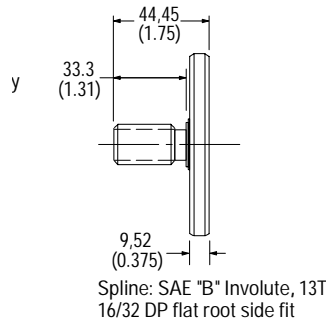
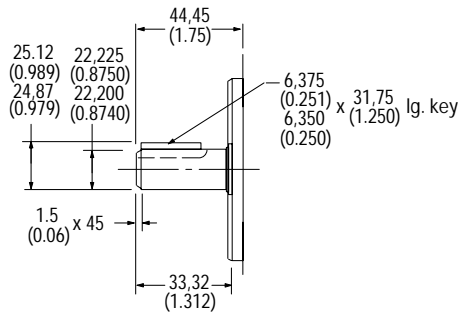

No. 10 Mounting and Input Shaft with VDMA Flange

(Flange and shaft end ISO 3019/2-100A2HW-E25N)

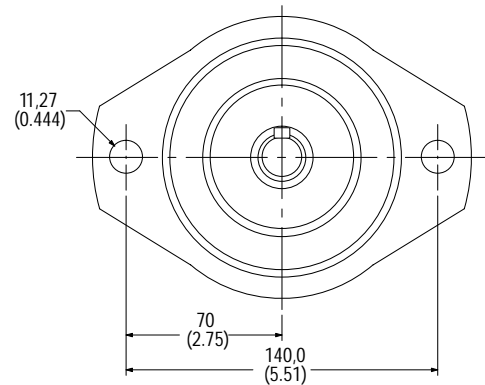
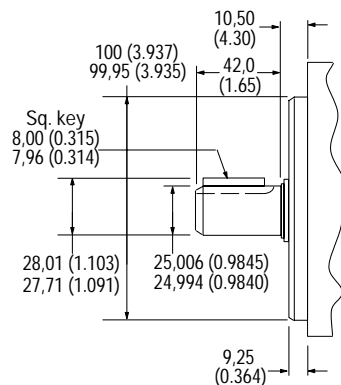

Pressure Compensator with Load Sensing

Remote Control

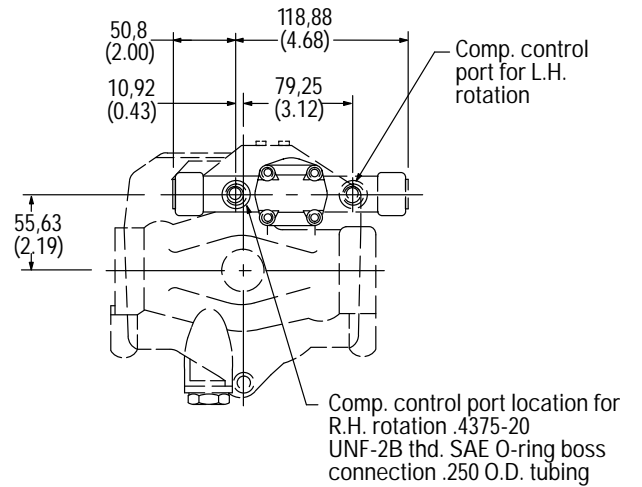
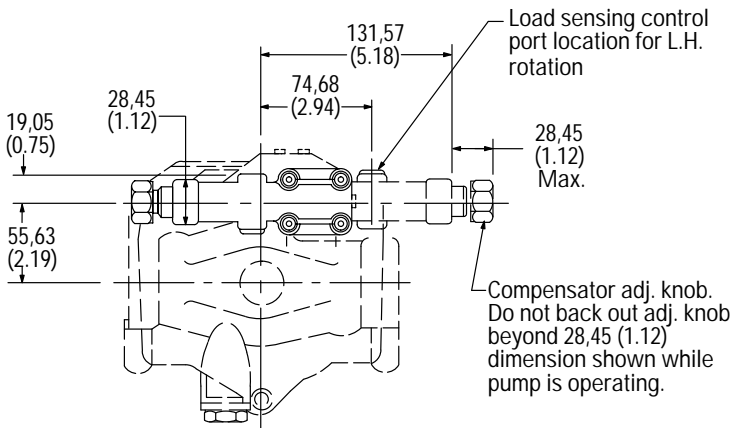
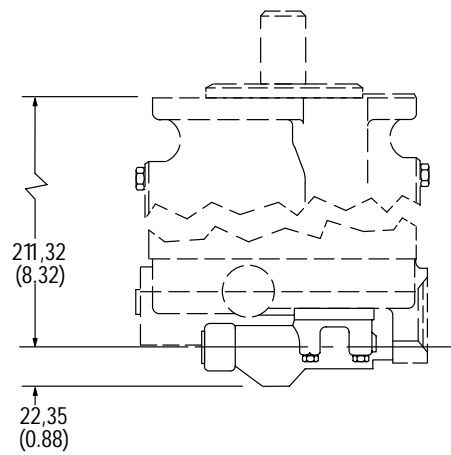
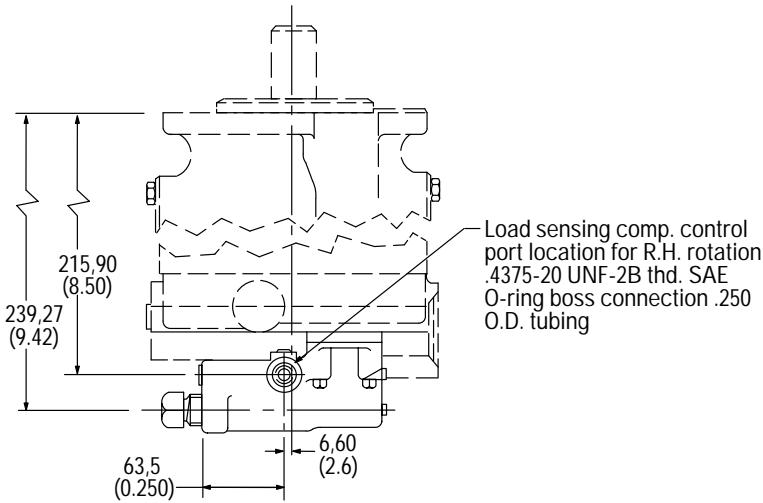

Controls Pressure Compensator Control with Adjustable Maximum Displacement Stop

Adjustment

Loosen locknut on adjusting rod. Turn adjusting rod clockwise (CW) to decrease maximum pump delivery or counterclockwise (CCW) to increase maximum pump delivery until desired setting is obtained. Secure this setting by tightening locknut. To assist initial priming, manual adjustment control setting must be at least 40% of maximum flow position.

This control enables the maximum pump delivery to be externally adjusted from 25% to 100% while maintaining all of the standard features of a pressure compensated pump.

Note: Not available with thru-drive models.

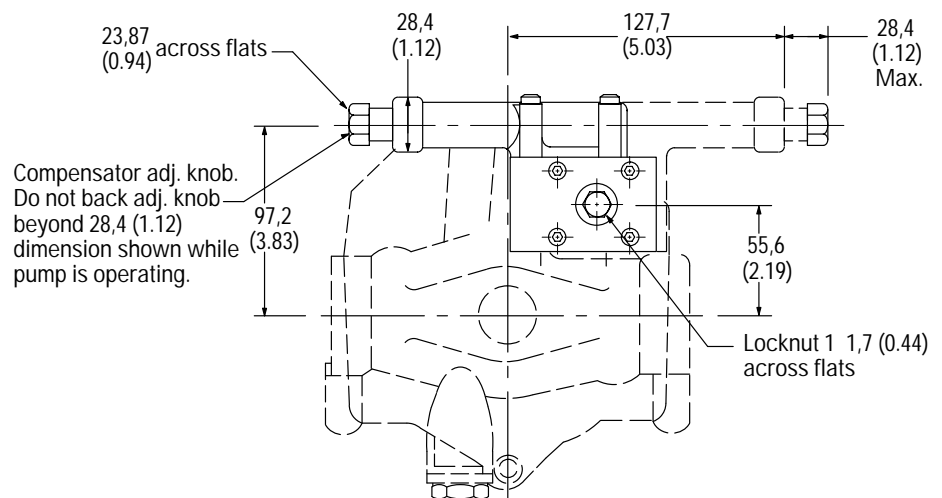
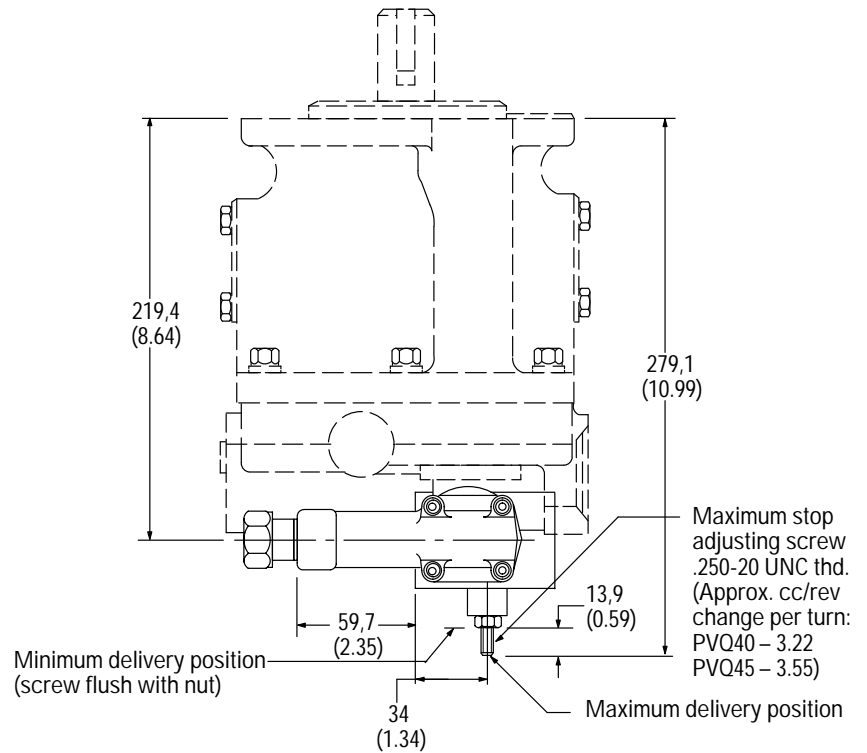

Controls

Electric Dual Range Pressure Compensator with Maximum Displacement Stop

See preceding page and following page for adjustment procedures.

Solenoid Data^u (110V AC 50 Hz and 115/120V AC 60 Hz)

Solenoid current	Inrush amps (R.M.S.)	Holding amps
115/120V AC 60 Hz -	2.0	.54
110V AC 50 Hz		.64*

*Maximum peak inrush amps approximately 1.4 x R.M.S. value shown.

Refer to catalog GB-C-2015B for additional solenoid valve data.

***Note:** Any sliding spool valve, if held shifted under pressure for long periods of time, may stick and not spring return due to fluid residue formation and, therefore, should be cycled periodically to prevent this from happening.

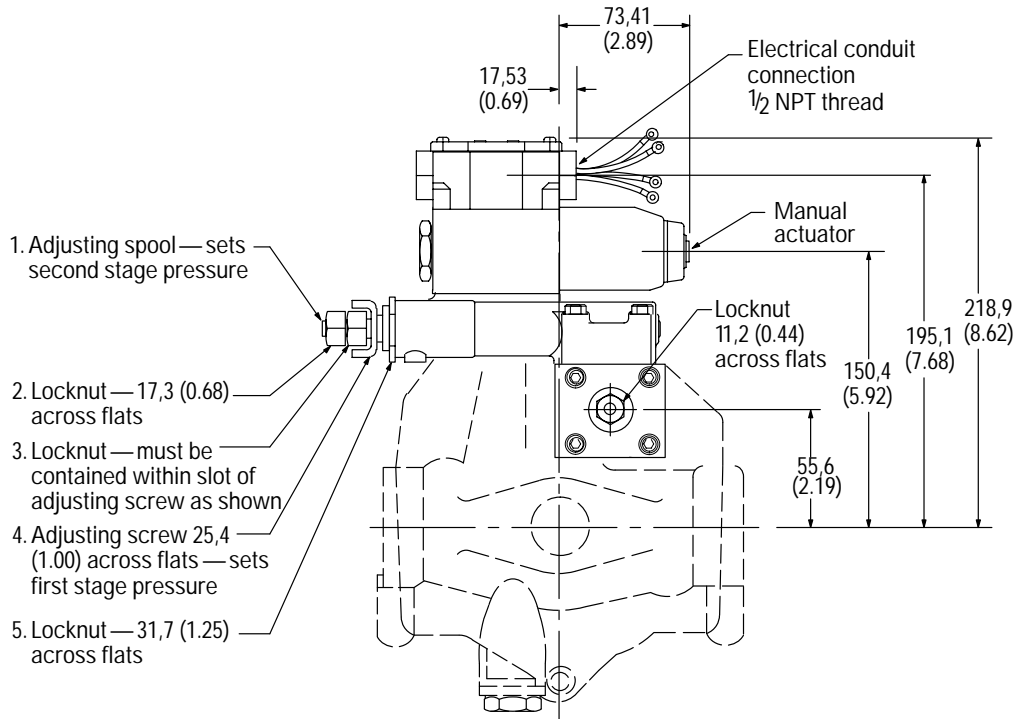
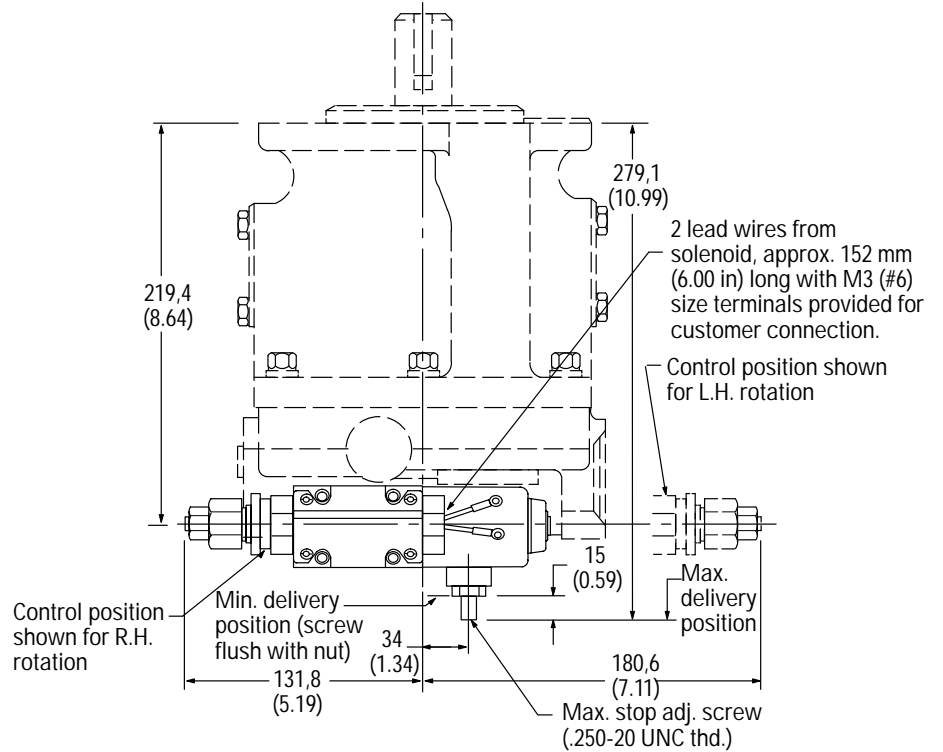

Controls

Electric Dual Range Pressure Compensator Control

Adjustment

1. With the directional valve de-energized, loosen locknut " 5" and turn the adjusting screw " 4" to the desired first stage pressure setting, then tighten locknut " 5".
2. With solenoid de-energized, turn adjusting spool " 1" counterclockwise (CCW) until nut " 3" is bottomed in adjusting screw slot. (Second stage setting is now equal to first stage pressure setting.) Turn adjusting spool clockwise (CW) to desired second stage pressure requirements. One complete turn of adjusting spool equals approximately 41 bar (600 psi). Energize solenoid and check pressure setting. De-energize solenoid and re-adjust if necessary. Secure this setting by tightening locknut " 2".

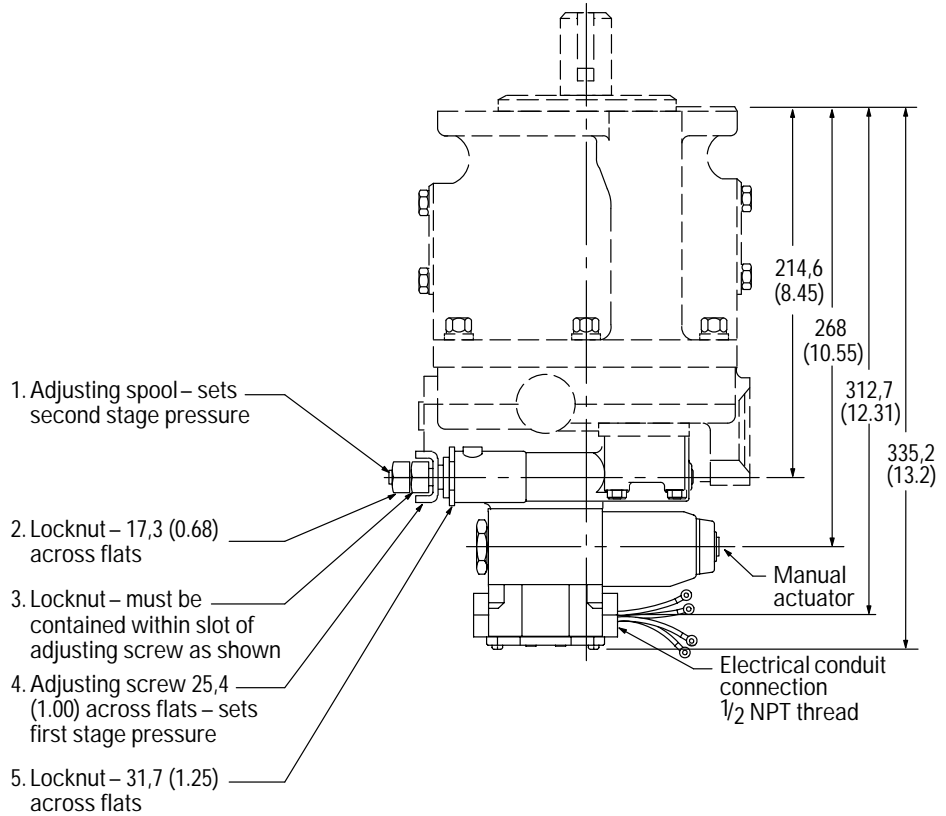

Solenoid Data^u (110V AC 50 Hz and 115/120V AC 60 Hz)

Solenoid current	Inrush amps (R.M.S.)	Holding amps
115/120V AC 60 Hz -	2.0	.54
110V AC 50 Hz		.64*

*Maximum peak inrush amps approximately 1.4 x R.M.S. value shown.

Refer to catalog GB-C-2015B for additional solenoid valve data.

Note: Any sliding spool valve, if held shifted under pressure for long periods of time, may stick and not spring return due to fluid residue formation and, therefore, should be cycled periodically to prevent this from happening.

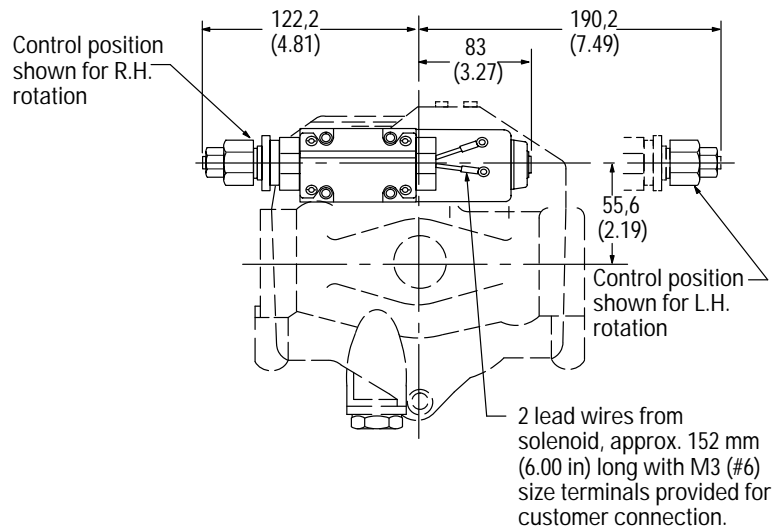

Controls

Unloading Valve Control – “E” Option

With the unloading valve control the variable pump will unload at a preset pressure. The pump will maintain this no flow, low pressure (approximately 14 bar [200 psi]) standby condition, until system pressure drops to about 85% of the preset unloading pressure. The pump will then return on stroke and provide full flow until the preset unloading pressure is reached again.

With this control, an efficient accumulator charging circuit is obtained. The pump will provide full flow to fill the accumulator until the maximum charging pressure is reached. The pump then goes to a standby condition until the accumulator pressure drops to 85% of the desired maximum. The accumulator is then recharged as the cycle starts over again.

A separate right angle check valve must be provided to maintain the accumulator hydraulic charge and prevent back flow when the pump is unloaded. The check valve's internal leakage must not exceed five drops per minute. The control port must be connected to system pressure, downstream of the check valve.

Adjustment range

PVQ40	100-210 bar (1500-3000 psi)
PVQ45	100-186 bar (1500-2700 psi)

Cut-in pressure is 85% of unloading pressure, minimum.

Setting Pressures

1. Back out accumulator unloading pressure adjustment screw to below desired unloading pressure.
2. Adjust desired standby pressure.
3. Set accumulator pressure by screwing in the accumulator unloading adjustment screw. Accumulator recharge (cut-in) pressure is a function of the maximum accumulator pressure and is not adjustable.
4. Check pressure settings and re-adjust if necessary.

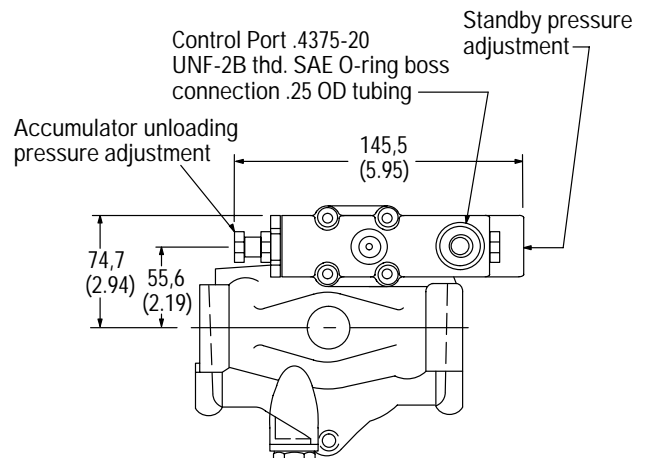
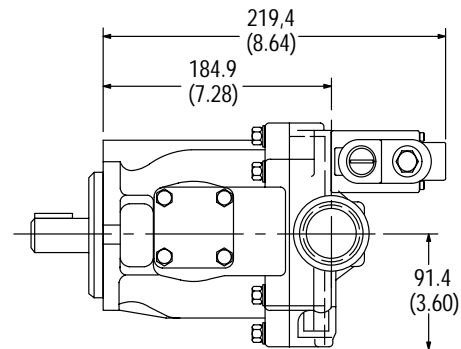
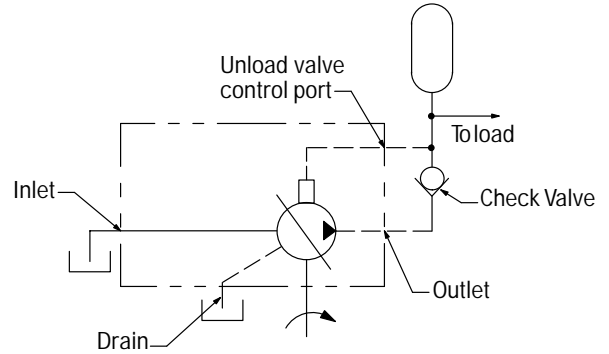

Thru-drives

PVQ40 and PVQ45 SAE "A"

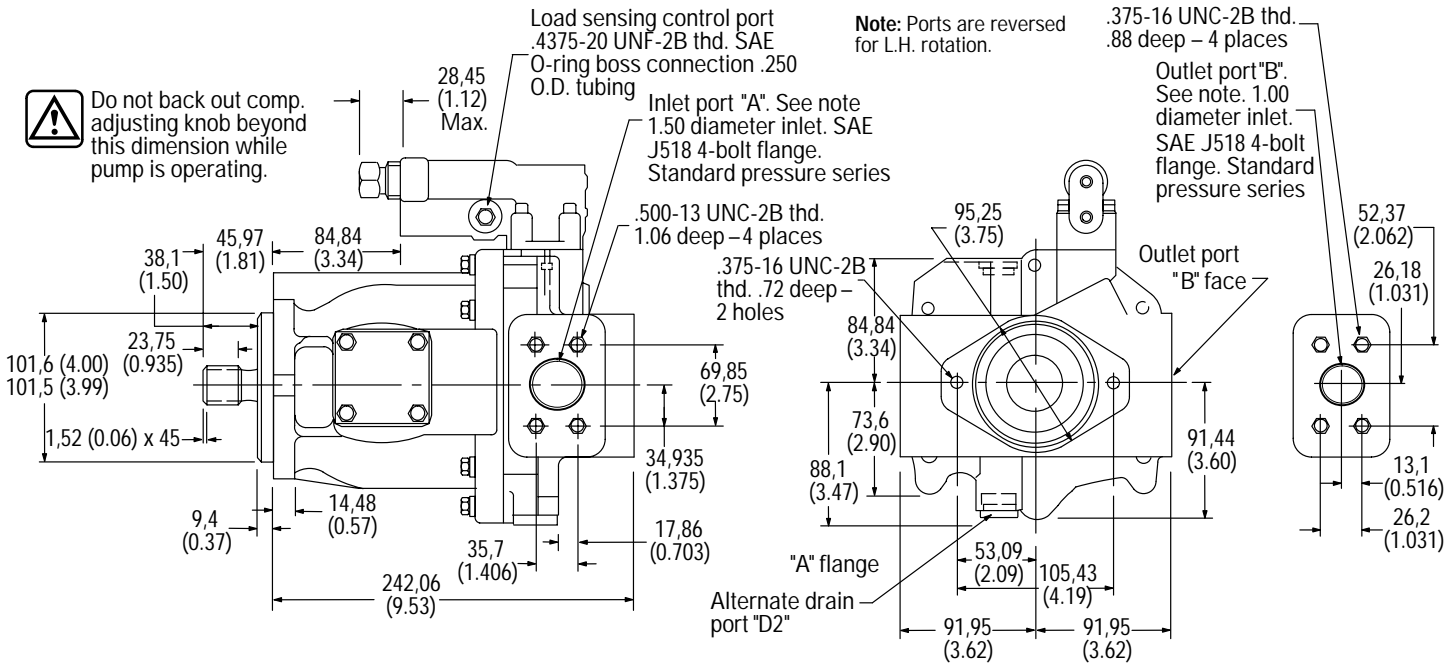
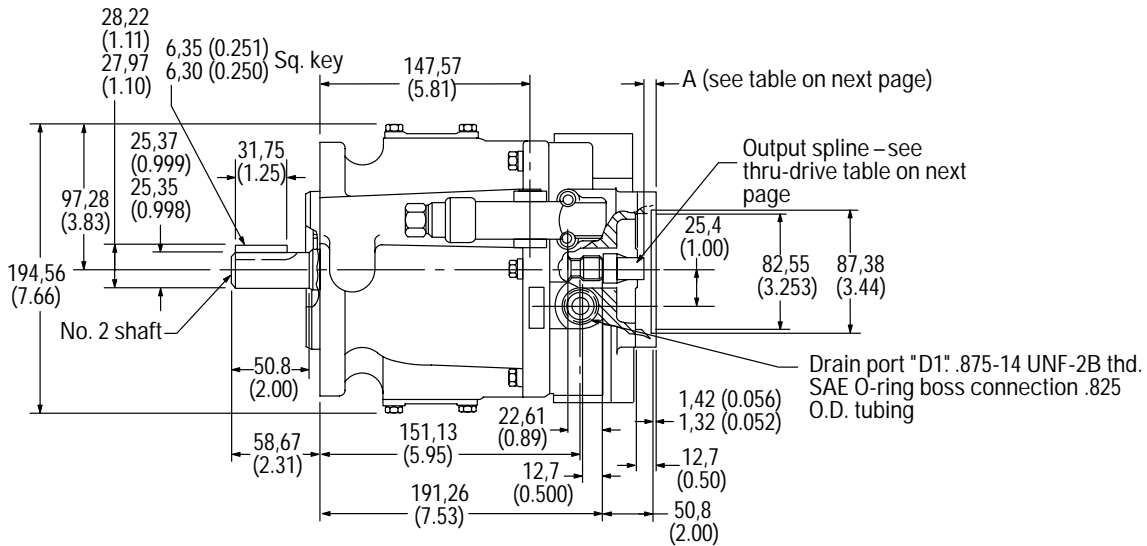

Thru-drives

PVQ40 and PVQ45 SAE "B"

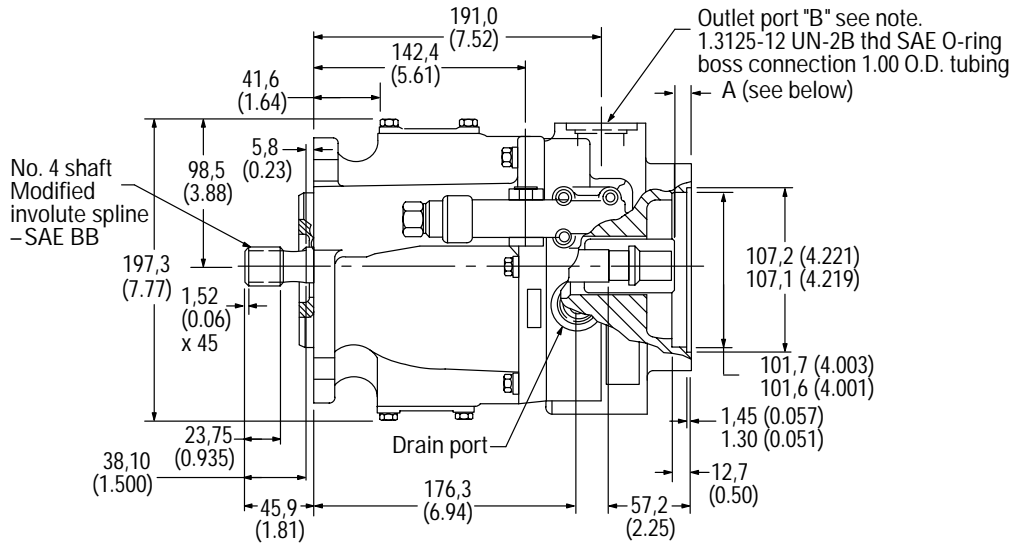

Donot back out comp. adjusting knob beyond this dimension while pump is operating.

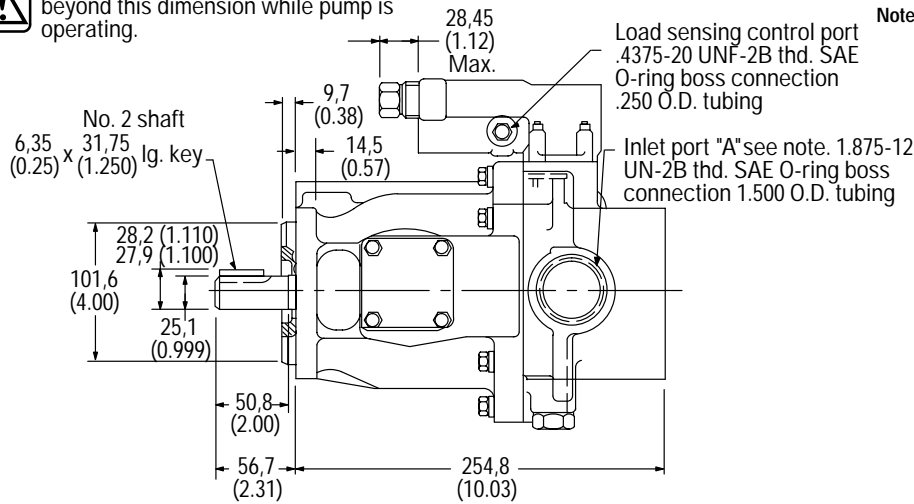

Note: Ports are reversed for L.H. rotation.

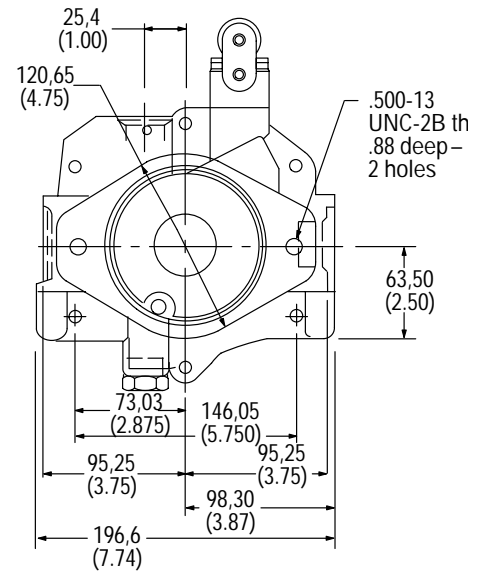

Thru-drive Shaft	Spline Data	Max. Torque Nm (in. lb.)	Dimension A mm (in.)	Coupling Type	Thru-drive Coupling
AA	ASA B5.15-1960 9 teeth 16/32 DP Flat root side fit	58 (517)	10.92 (0.43)	9T/9T	864224
AB	ANS B92.1-1970 11 teeth 16/32 DP Flat root side fit	118 (1050)	12.57 (0.495)	11T/11T	864325
AE	Special Eaton 26 teeth 32/64 DP Flat root side fit	179 (1587)	24.89 (0.98)	26T/26T	627168
			10.92 (0.43)	26T/13T	864307
			20.56 (0.81)	26T/15T	475134

Note: Coupling, screws, and washers must be ordered separately to mount rear pump. "A" O-ring (AS568-042) and "B" O-ring (AS568-155) are included with each thru-drive pump. Couplings for "B26" are step type for 13 and 15 tooth as shown.

Thru-drives Shaft Torque Data PVQ40/45

THRU-DRIVE SHAFT TORQUE DATA

Shaft	Input Shaft Code	Maximum Input Torque Total Nm (lb. in.)	Maximum Thru-drive Torque Output Nm (lb. in.)
9T	2	215 (1900)	58 (517)
	5	208 (1850)	
	8	337 (2987)	
11T	2	215 (1900)	123 (1100)
	5	208 (1850)	
	8	337 (2987)	
26T	2	215 (1900)	179 (1587)
	5	208 (1850)	
	8	337 (2987)	

Note: Both input and output limits must be met.

Typical Rear Pumps (with Shaft Codes) for PVQ40/45 Thru-drives

TYPICAL REAR PUMPS (WITH SHAFT CODES) FOR PVQ40/45 THRU-DRIVES

Thru-drive shaft	Typical Rear Pump	Rear Pump Shaft Code	Thru-drive Coupling		
9T	PVQ10/13	3	864224		
	PVB5/6	S124 suffix			
	V10	11			
	V20	62			
26T	PVE012	2	864307		
		28	627168		
	PVQ20/32	3	864307		
		28	627168		
	PVQ40/45	28	3	864307	
			4	475134	
		V2010 OR V2020	28	627168	
			11	864307	
			20V	151	864307
			2520V	166	475134

Note: 11T (not listed above) is intended for special application only.

Thru-drives PVQ40 and PVQ45 Pump Support Bracket

An optional support bracket should be used when a heavy second pump is mounted to a thru-drive PVQ40 or PVQ45. The support bracket (627179), two screws (199740), and two washers (427700) must be ordered separately.

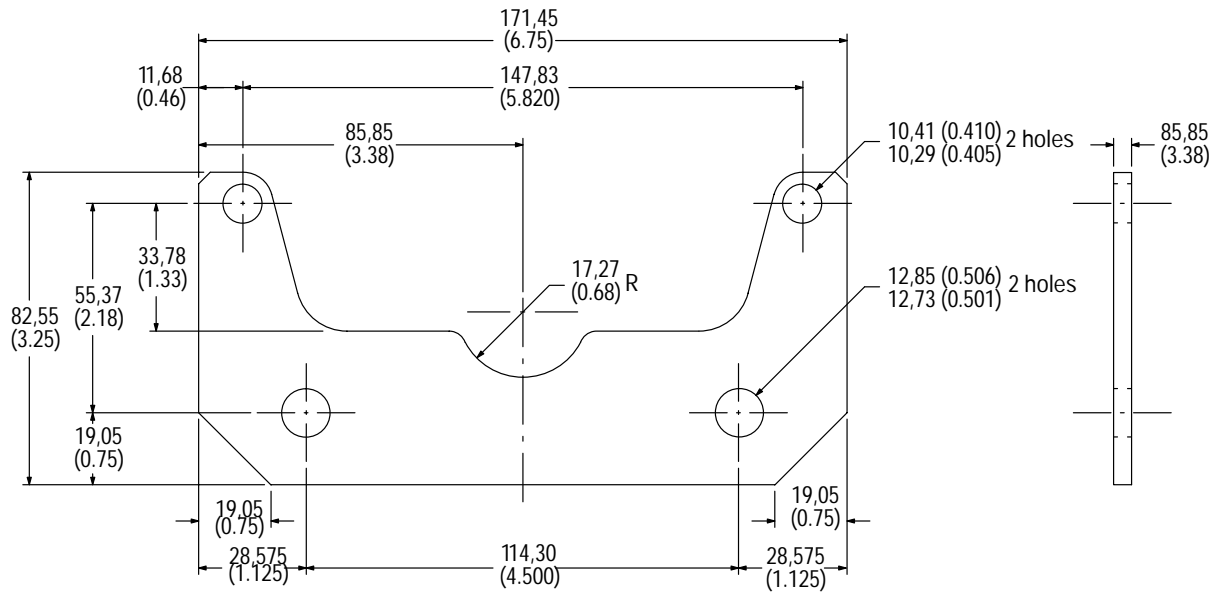

Application Data Fluid Cleanliness

Proper fluid condition is essential for long and satisfactory life of hydraulic components and systems. Hydraulic fluid must have the correct balance of cleanliness, materials, and additives for protection against wear of components, elevated viscosity, and inclusion of air.

Essential information on the correct methods for treating hydraulic fluid is included in

Eaton publication 561 "Eaton Guide to Systemic Contamination Control" available from your local Eaton distributor or by contacting Eaton. Recommendations on filtration and the selection of products to control fluid condition are included in 561.

Recommended cleanliness levels, using petroleum oil under common conditions, are based on the highest fluid pressure

levels in the system and are coded in the chart below. Fluids other than petroleum, severe service cycles, or temperature extremes are cause for adjustment of these cleanliness codes. See Eaton publication 561 for exact details.

Eaton products, as any components, will operate with apparent satisfaction in fluids with higher cleanliness codes

than those described. Other manufacturers will often recommend levels above those specified. Experience has shown, however, that life of any hydraulic component is shortened in fluids with higher cleanliness codes than those listed below. These codes have been proven to provide a long, trouble-free service life for the products shown, regardless of the manufacturer.

Product	System Pressure Level bar (psi)		
	<70 (<1000)	70-210 (1000-3000)	210+ (3000+)
Piston Pumps – Variable	18/16/14	17/15/13	16/14/12

Hydraulic Fluids and Temperature Ranges

Use antiwear hydraulic oil, or automotive type crankcase oil designations SC, SD, SE or SF per SAE J183FEB80.

Select a viscosity grade that will allow optimum viscosity, between 40 cSt (180 SUS) and 16 cSt (80 SUS), to be achieved within the optimum performance envelope shown below.

For further information, see Eaton data sheet B-920 or I-286-S.

Fire Resistant Fluids

All pumps can be used with water glycol and polyol ester fluids. All pumps can be operated to 140 bar (2000 psi) with these fluids, except PVQ13 and PVQ32 which are limited to 105 bar (1500 psi). Input speed should not exceed 1800 r/min. System temperature should not exceed 54° C (130° F). Inlet vacuum should not exceed 101,6 millibar (3 in. Hg). For more information, refer to Eaton publication 579.

Installation and Start-up (Commissioning)

Before a pump is started, fill the case through the uppermost drain port with hydraulic oil of the type to be used. The case drain line must be connected to the reservoir below oil level.

For multiple pump arrangements that include non-PVQ sections, the requirements of the non-PVQ units must be considered.

Ordering Procedure

Order pumps by the full model designation. Pump displacement, mounting flange type, direction of rotation, pump configuration, shaft end type, seals, pressure adjustment range, and specific control functions are all specified in the full model number system.

Couplings, O-rings, capscrews and washers must be ordered separately for all thru-drive pumps.

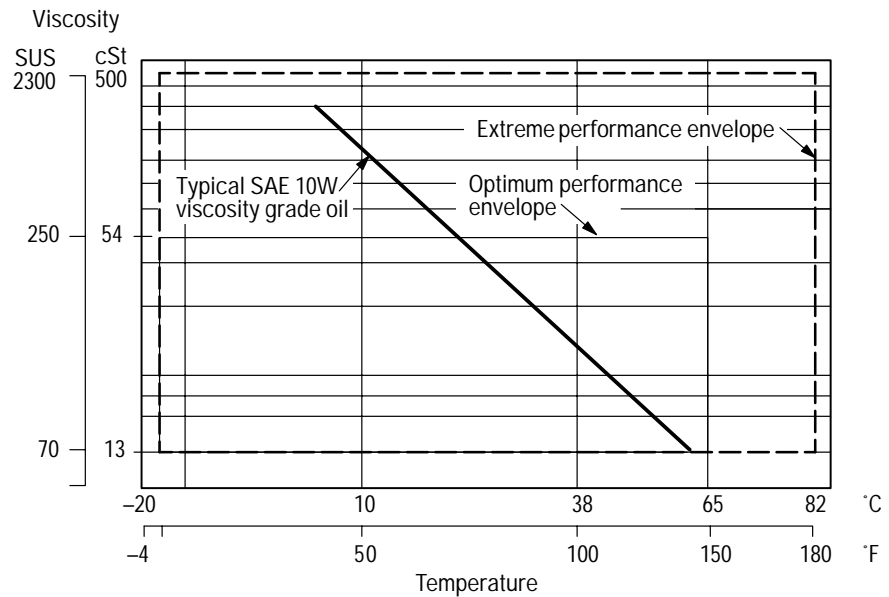

Eaton
14615 Lone Oak Road
Eden Prairie, MN 55344
USA
Tel: 952 937-9800
Fax: 952 974-7722
www.hydraulics.eaton.com

Eaton
20 Rosamond Road
Footscray
Victoria 3011
Australia
Tel: (61) 3 9319 8222
Fax: (61) 3 9318 5714

Eaton
46 New Lane, Havant
Hampshire PO9 2NB
England
Tel: (44) 23 92 486 451
Fax: (44) 23 92 487 110



© 2002 Eaton Corporation
All Rights Reserved
Printed in USA
Document No. V-PP-MC-0002-E
Supercedes 11-06-0002-EN-0801
December 2002