

Powering Business Worldwide

Table of Contents

Service Parts

Parts identification	4
Exploded assembly	6
Optional assembly	7
Typical cross section	9
Drive shaft & key	10
End cover	11
Valve plate & Housing	12
Swash plate, Rotating groups & Shaft seals	13
Compensator kits - factory set	14
Compensator mounting screws, Control piston & Plug, adjustable volume stop	15
Plug sub-assemblies, Coupler & Cover plate	16
Hex head cap screw (cover plate), Cold start manifold (destroke) & Electronic displacement control S/A	17

Repair

220 Mobile piston pump repair	18
General information	19
Pump repair	20
Inspection, repair and part replacement	23
Assembly	26
Testing	28
Assembly torque values	29

Part identification

Item	Part number	Quantity	Description	Page number
1	See table 1	1	Shaft, drive	10
2	6028118-XXX	AR	Spacer, bearing / bearing shim kit ■	25
3	See table 1	1	Key, driveshaft	10
4	See table 2	1	End cover S/A	11
5	16026-610	1	Roll pin	6
6	See table 3	1	Valve plate	12
7	104166-156	1	O-ring ●	6
8	See table 4	1	Housing	12
9	388153	1	Bearing assembly, shaft (front)	6
10	02-335336	1	Bearing assembly, shaft (rear)	6
11	6026924-001	2	Bearing, swash plate	6
12	114995-010	2	Screw, cap, socket	6
13	5992034-001	1	Spring, bias	6
14	See table 5	1	Swash plate	13
15	See table 6	1	Rotating group S/A	13
16	114977-035	4	Screw, cap (housing / end cover)	6
17	See Table 7	1	Seal, shaft, fluorocarbon ●	13
18	16077-032	1	Ring, retaining, internal (shaft seal) ●	6
19	See Table 8	1	Compensator kits	14
20	107275-011	4	O-ring (secondary compensator / housing) ●	6
21	107275-017	1	O-ring (compensator / housing) ●	6
22	See Table 9	4	Screw, cap (compensator mounting)	15
23	See Table 10	1	Piston, control	15
24	See Table 11	1	Plug, fixed volume stop ◆	15
25	16103-302	2	Plug (diagnostic ports)	16
26	See table 12	3	Plug (bottom, top and side case drain ports)	16

- Standard Seal Kit: 9900959-000
- ◆ Adjustable Maximum Displacement Volume Stop Kit: 9900958-000
- Shaft bearing Shim Kit: 9900961-000

Part identification

Item	Part number	Quantity	Description	Page number
27	See table 12	1	Plug (vertical case drain port)	16
28	See table 12	1	Plug (diagnostic port)	16
29	6026914-001	1	Link, feedback (feedback sensor option)	8
30	114995-010	1	Screw, cap, socket, flat, countersunk (feedback sensor option)	8
31	5990203-001	1	Magnet carrier (feedback sensor option)	8
32	54999158	1	Adapter, swash sensor (feed sensor option)	8
33	104166-021	1	O-ring (adapter / swash sensor assy) ● (feedback sensor option)	8
34	6024371-002	1	Feedback sensor, non-contact (feedback sensor option)	8
35	6027085-001	2	Screw, cap S/A (swash sensor) (feedback sensor option)	8
36	16026-406	1	Pin, roll (feedback link) (feedback sensor option)	8
37	6030096-350	1	Screw, cap ◆ (adjustable maximum stop option)	8
38	692866	1	Nut sealing ◆ (adjustable maximum stop option)	8
39	16133-12	1	O-ring ◆ (adjustable maximum stop option)	8
40	937166	2	Tamper proof cap	–
42	See table 13	1	Coupler	16
44	104166-154	1	O-ring, adaptor	–
49	See Table 14	1	Cover plate	16
50	See Table 15	4	Screw, cap hex socket head (cover plate)	17
53	See Table 16	1	Cold start manifold (destroke)	17
56	See Table 17	1	Electronic displacement control S/A	17
57	6040934-001	1	Spring, feedback	7
58	473712	4	Screw, hex socket	7
59	6035825-012	1	Coil, 12V	7
60	6041646-001	1	Check valve	7

- Standard Seal Kit: 9900959-000
- ◆ Adjustable Maximum Displacement Volume Stop Kit: 9900958-000
- Shaft bearing Shim Kit: 9900961-000

Exploded assembly

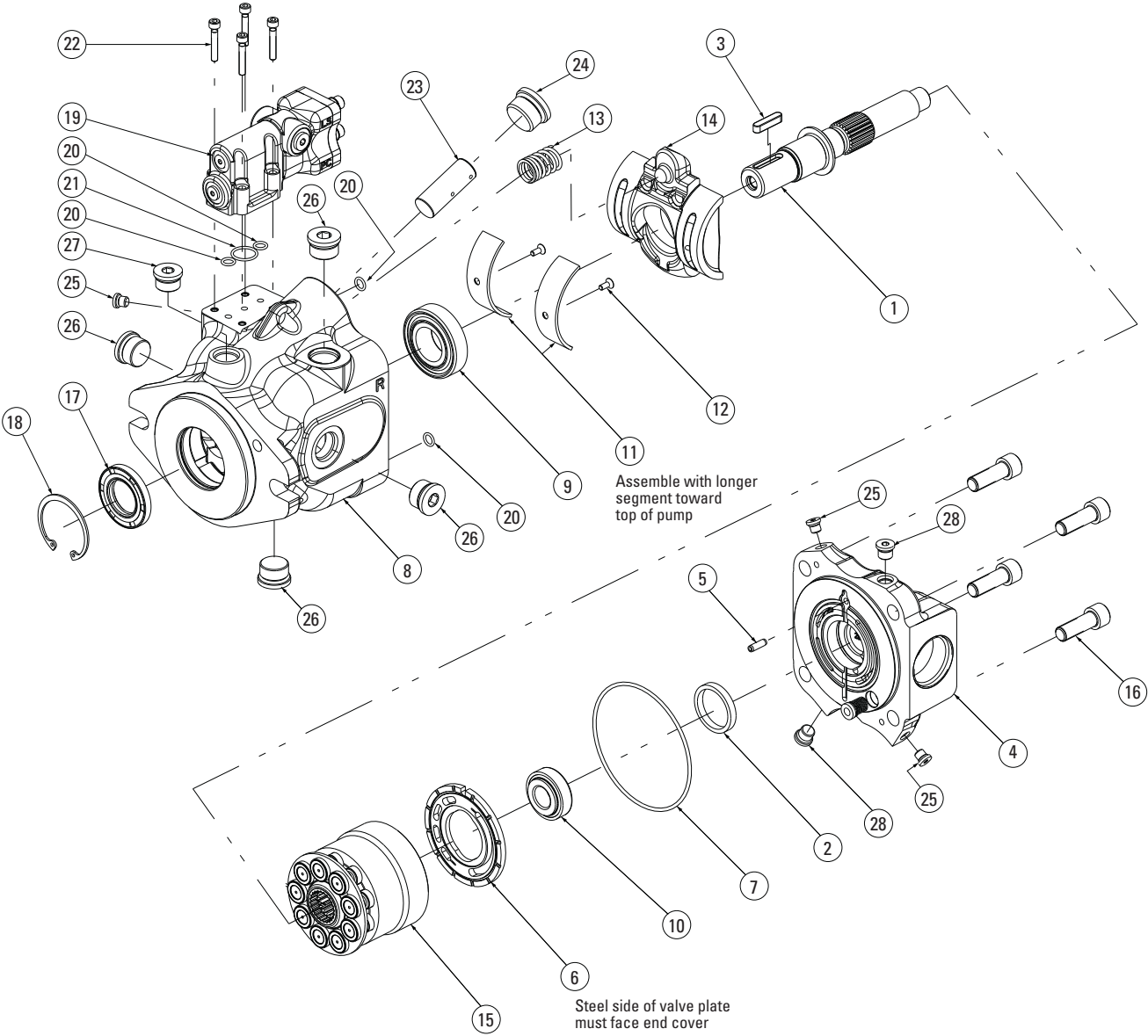

Optional assembly

Electronic displacement control option

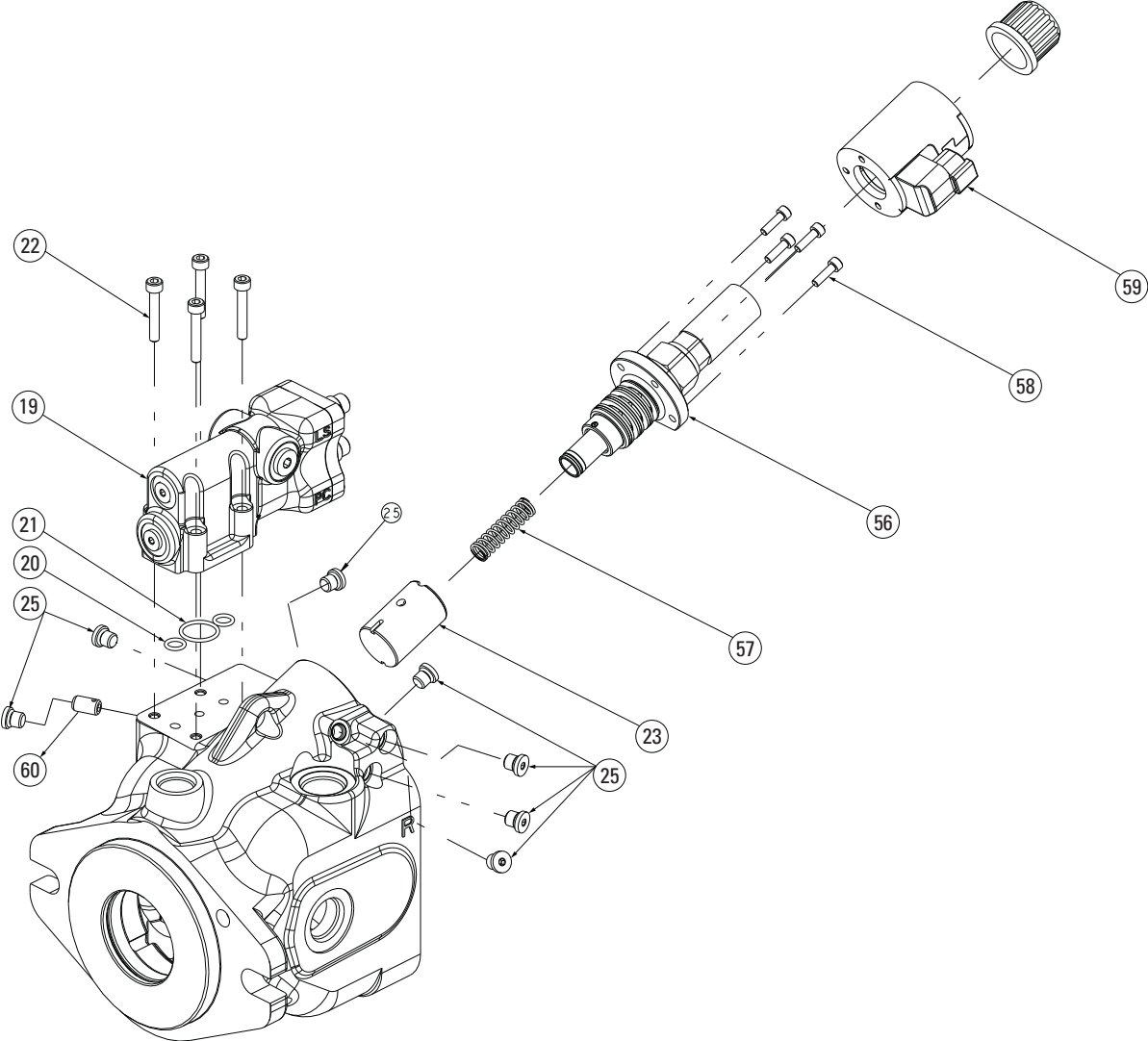

Optional assembly

Feedback sensor option

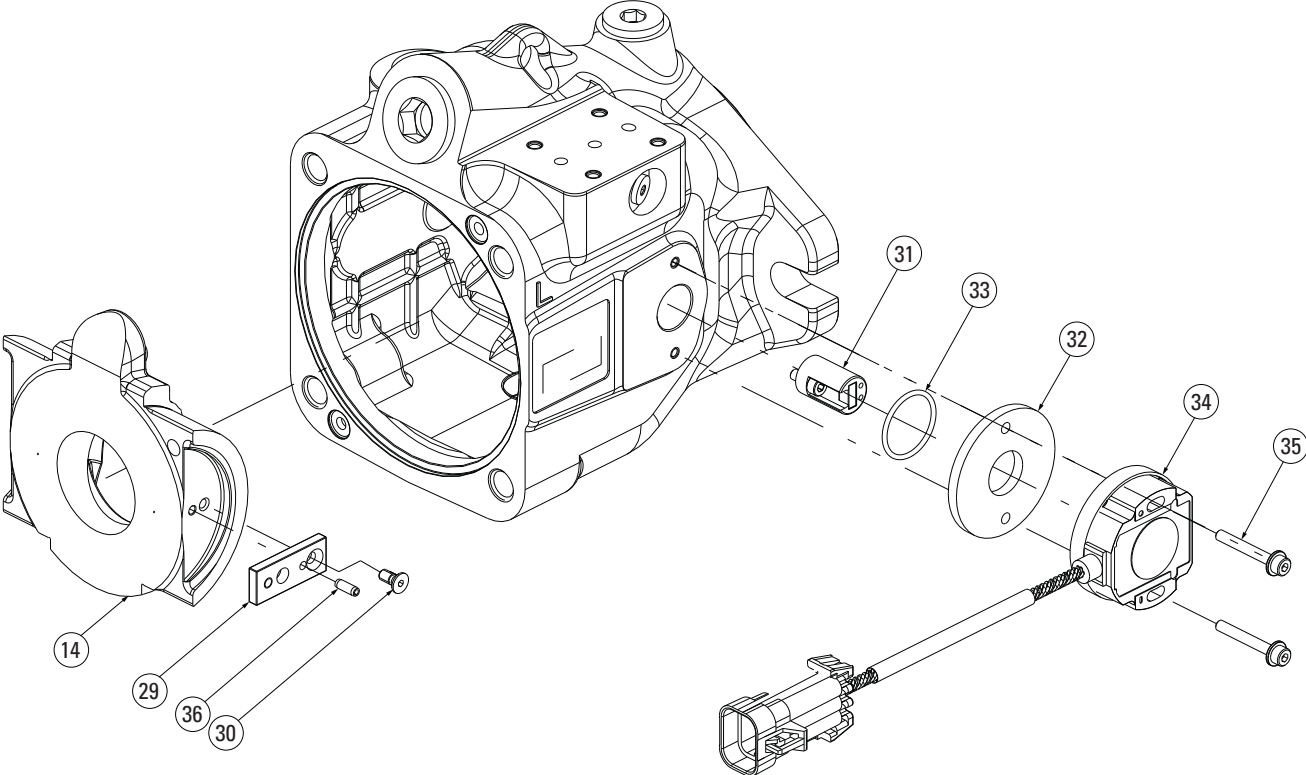

Adjustable maximum stop option

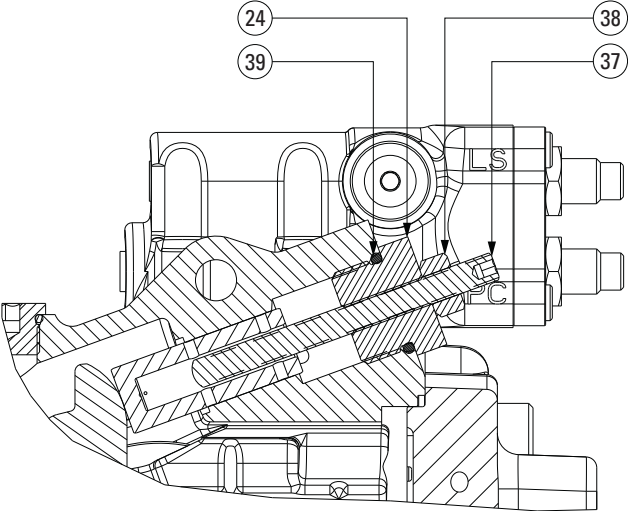

Typical cross section

Side view

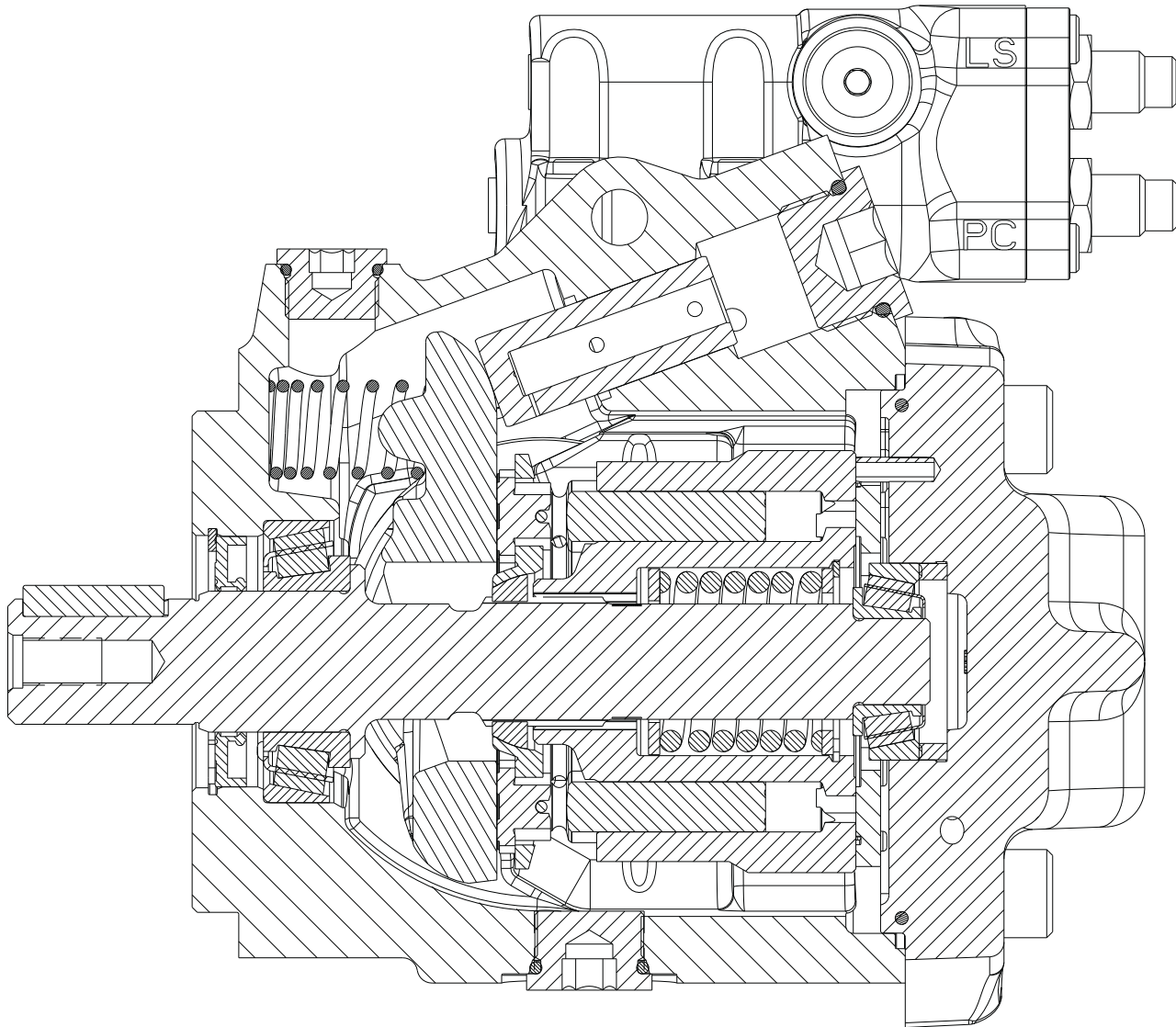

Drive shaft & key - Items 1 & 3

Table 1

Table 1. Drive shaft & key (Items 1 & 3)

Code position 4, 5, 6	8, 9	26, 27	Key (Item 3)	Part number	Description
028	05	00	24500-619	6026704-003	Shaft, drive, 22.2 dia. straight key, 41 mm ext.
028	09	00	-	6026704-001	Shaft, drive, input 13 tooth 16/32, 41 mm ext.
028	31	00	16246-516	6026704-002	Shaft, drive, 25.4 dia. straight key, 46 mm ext.
028	34	00	-	6026704-004	Shaft, drive, input 15 tooth 16/32, 46 mm ext.
028	34	AC,AA	-	6034050-001	Shaft, drive, input 15 tooth 16/32, 46 mm ext.
028	09	AC,AA	-	6034050-002	Shaft, drive, input 13 tooth 16/32, 41 mm ext.
028	05	AA,AC	24500-619	6034050-003	Shaft, drive, 22.2 dia. straight key, 41 mm ext.
028	31	AC,AB,AA	16246-516	6034050-004	Shaft, drive, 25.4 dia. straight key, 46 mm ext.

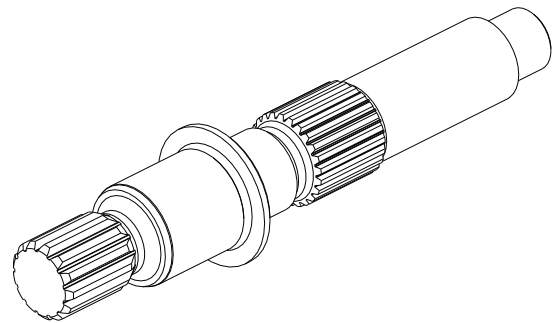

End cover - Item 4

Table 2

Table 2. End cover (Item 4)

Code position 4, 5, 6	10, 11	13	26, 27	Part number	Description
028	AB	1	0	6026786-001	Endcover S/A, side port (O-ring port)
028	AA	1	0	6026786-002	Endcover S/A, rear port (O-ring port)
028	AF	1	0	6026786-003	Endcover S/A, side port (SAE 4 bolt flange port)
028	AE	1	0	6026786-004	Endcover S/A, rear port (SAE 4 bolt flange port)
028	AD	2	0	6026786-005	Endcover S/A, side port metric
028	AC	2	0	6026786-006	Endcover S/A, rear port metric
028	AG	1	0	6026786-007	Endcover S/A, side port (4 bolt flange port)
028	AB	1	AC, AA, AB	6034047-001	Endcover S/A, side port (O-ring port), thru drive
028	AF	1	AC, AD	6034047-002	Endcover S/A, side port (SAE 4 bolt flange port), thru drive
028	AG	1	AC	6034047-003	Endcover S/A, side port (4 bolt flange port), thru drive
028	AD	2	AA, AC, AB	6034047-004	Endcover S/A, side port metric, thru drive

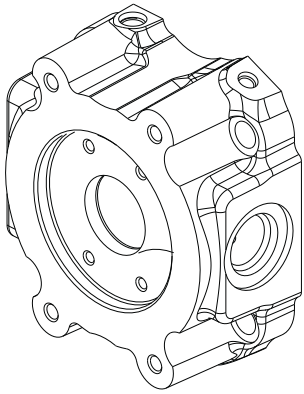

Thru-drive

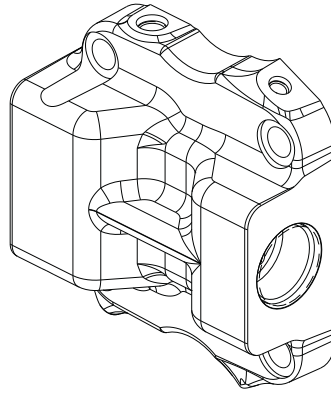

Side ported

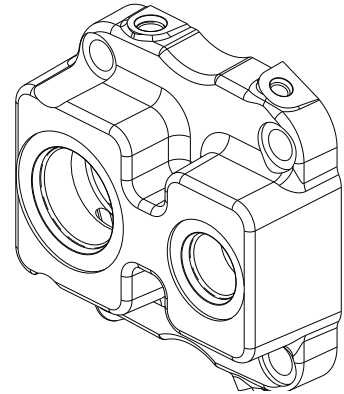

Rear ported

Valve plate - Item 6

Housing - Item 8

Table 3 & 4

Table 3. Valve plate (Item 6)

Code position 4, 5, 6	7	Part number	Description
028	R	6029630-001	Plate, valve RH
028	L	6029630-002	Plate, valve LH

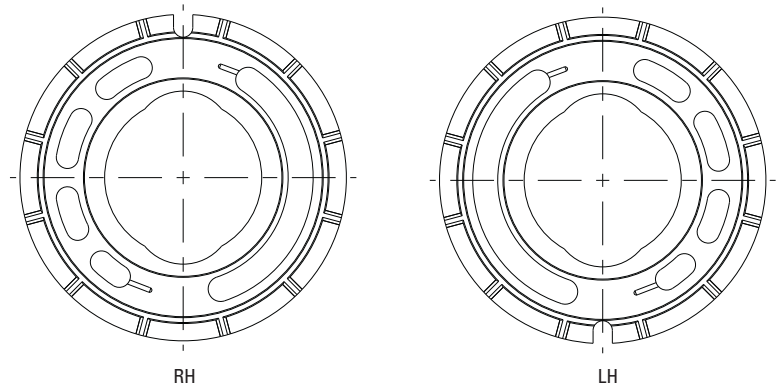
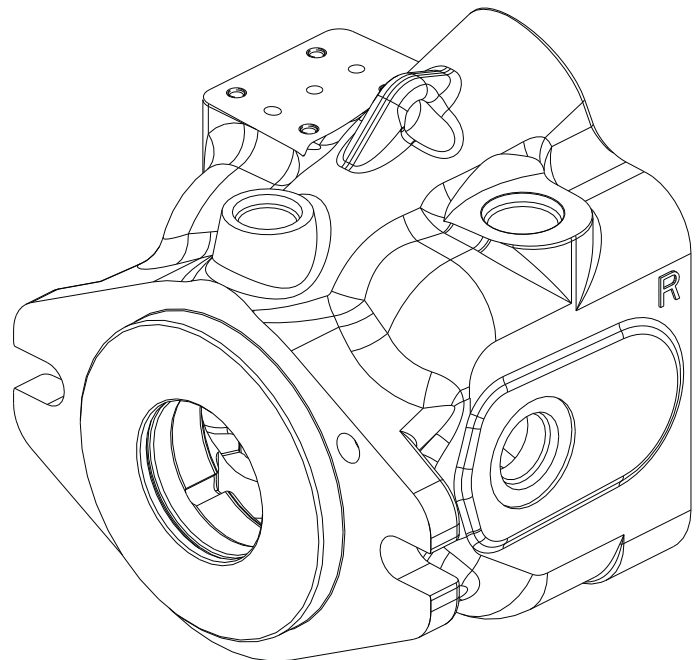

Table 4. Housing (Item 8)

Code position 8,9	12	29, 30	Part number	Description
05, 09, 31, 34	A, B, G	AB	6026919-001	Housing (Swash sensor)
05, 09, 31, 34	A, B, E, G	00	6026919-002	Housing
05, 09, 31, 34	C, D, F	00	6026919-003	Housing metric
05	A	00	6039838-001	Housing, EDC



Swash plate - Item 14

Rotating groups - Item 15

Shaft seals - Item 17

Table 5, 6 & 7

Table 5. Swash plate (Item 14)

Code position 4, 5, 6	Part number	Description
028	6026917-001	Swashplate

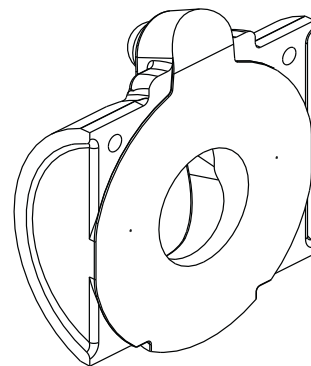

Table 6. Rotating groups (Item 15)

Code position 4, 5, 6	Part number	Description
028	6026982-001	Rotating group S/A 28cc

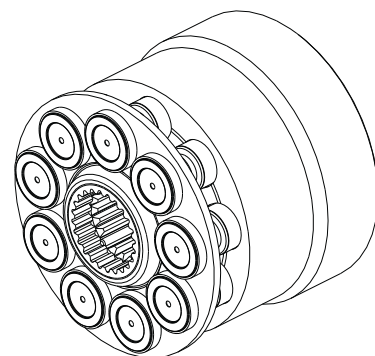
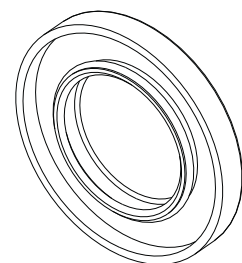

Table 7. Shaft seals (Item 17)

Code position 8, 9	28	Part number	Description
Not 32,33	2,3,6	16253-218	Seal, shaft, fluorocarbon, SAE B
Not 32,33	4	16253-18	Seal, shaft, nitrile, SAE B



Compensator kits - Items 19, 20, 21 & 22

Table 8 - Factory set

Table 8. Compensator kits (Items 19, 20, 21 & 22)

Code position 14, 15	16,17	Pressure limit setting	18,19	Flow setting	22, 23	Kit number
AA	28	206.8-213.7 Bar [3000-3100 lbf/in ²]	23	23.10-25.17 Bar [335-365 lbf/in ²]	00	9901219-001
AA	32	226.5-233.4 Bar [3285-3385 lbf/in ²]	16	13.79-16.55 Bar [200-240 lbf/in ²]	00	9901219-002
AA	27	199.9-206.8 Bar [2900-3000 lbf/in ²]	25	23.44-26.89 Bar [340-390 lbf/in ²]	00	9901219-003
AA	43	275.8-282.7 Bar [4000-4100 lbf/in ²]	16	13.79-16.55 Bar [200-240 lbf/in ²]	00	9901219-008
AA	39	258.6-265.4 Bar [3750-3850 lbf/in ²]	28	26.20-28.96 Bar [380-420 lbf/in ²]	00	9901219-049
AA	15	151.7-158.6 Bar [2200-2300 lbf/in ²]	34	4.50-6.90 Bar [66-100 lbf/in ²]	00	9901219-063
AA	19	168.9-175.8 Bar [2450-2550 lbf/in ²]	20	17.24-19.99 Bar [250-290 lbf/in ²]	00	9901219-080
AA	12	137.9-144.8 Bar [2000-2100 lbf/in ²]	10	9.65-12.41 Bar [140-180 lbf/in ²]	00	9901219-081
AA	35	241.3-248.2 Bar [3500-3600 lbf/in ²]	14	12.41-15.17 Bar [180-220 lbf/in ²]	00	9901219-028
AB	28	206.8-213.7 Bar [3000-3100 lbf/in ²]	24	22.75-25.51 Bar [330-370 lbf/in ²]	00	9901219-012
AB	43	275.8-282.7 Bar [4000-4100 lbf/in ²]	24	22.75-25.51 Bar [330-370 lbf/in ²]	00	9901219-011
AB	27	199.9-206.8 Bar [2900-3000 lbf/in ²]	17	15.86-18.62 Bar [230-270 lbf/in ²]	00	9901219-040
AC	12	137.9-144.8 Bar [2000-2100 lbf/in ²]	00	No flow comp. setting	00	9900512-021
AC	19	168.9-175.8 Bar [2450-2550 lbf/in ²]	00	No flow comp. setting	00	9900512-023
AC	21	179.3-186.2 Bar [2600-2700 lbf/in ²]	00	No flow comp. setting	00	9900512-029
AC	28	206.8-213.7 Bar [3000-3100 lbf/in ²]	00	No flow comp. setting	00	9900512-016
AC	43	275.8-282.7 Bar [4000-4100 lbf/in ²]	00	No flow comp. setting	00	9900512-009
AC	45	306.8-313.7 Bar [4450-4550 lbf/in ²]	00	No flow comp. setting	00	9900512-004

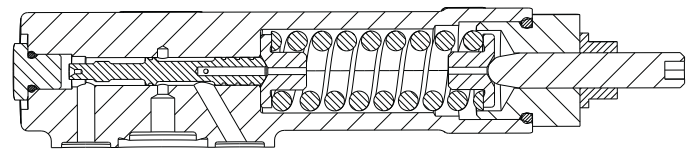
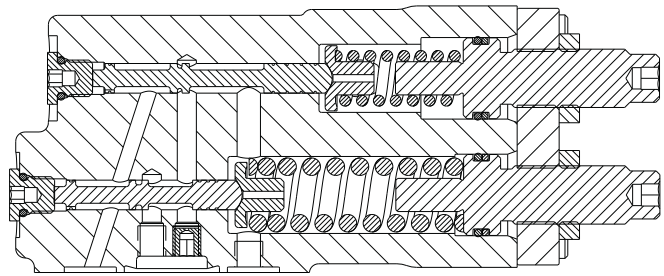
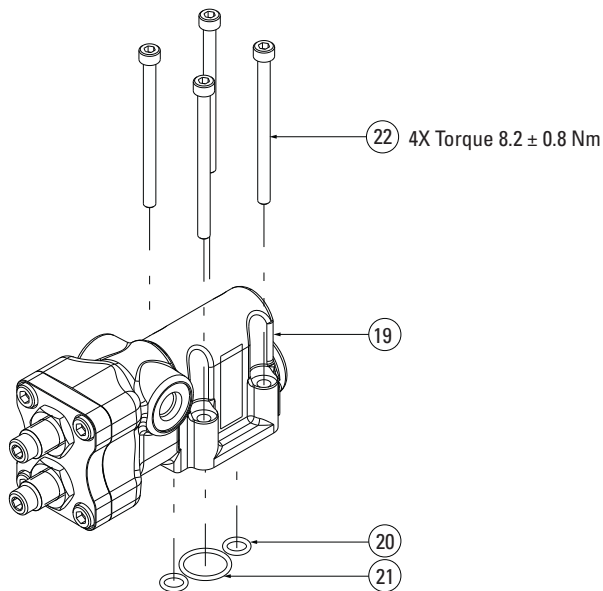

Compensator mounting screws - Item 22

Control piston - Item 23

Plug, adjustable volume stop - Item 24

Table 9, 10 & 11

Table 9. Compensator mounting screws (Item 22)

Code position 14, 15	22, 23	Part number	Description
AA, AB, AT, AY	-	114953-030	Screw, cap (Compensator mounting)
AA, AC	OC, OK	114953-060	Screw, cap (Compensator/manifold mounting)
AV	-	114953-070	Screw, cap (Compensator mounting)

Table 10. Control piston (Item 23)

Code position 14, 15	Part number	Description
Not AT, AY	6030097-001	Piston, control
AT, AY	6039060-001	Piston, control EDC

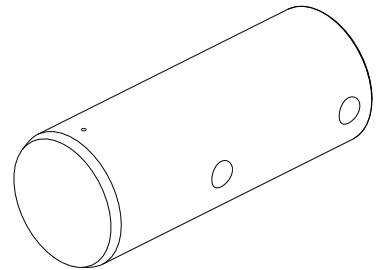
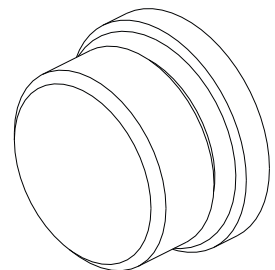

Table 11. Plug, adjustable volume stop (Item 24)

Code position 24, 25	Part number	Description
01	16103-312	Plug
02, 03, 04, 05	6030098-001	Plug, max displacement



Plug sub-assemblies - Item 26, 27 & 28

Coupler - Item 42

Cover plate - Item 49

Table 12, 13 & 14

Table 12. Plug sub-assemblies (Item 26, 27 & 28)

Code position 12	13	29, 30	Part number	Description
A, B, E, G	-	00, AB	16103-310	Plug (bottom, side and top case drain) 0.875-14 UNF-2B Thd.
C, D, F	-	00, AB	9237-005	Plug (bottom, side and top case drain) M22 X 1.5 Thd.
A, B, E	-	-	16103-308	Plug (vertical case drain) 0.750-16 UNF-2B Thd.
C, D, F	-	-	9237-004	Plug (vertical case drain) M18 X 1.5 Thd.
-	1	-	16103-304	Plug (diagnostic ports) 0.4375-20 UNF-2B Thd.
-	2	-	9237-002	Plug (diagnostic ports) M12 X 1.5 Thd.

Table 13. Coupler (Item 42)

Code position 26, 27	Part number	Description
AC	6034051-001	Coupler, 21/13 tooth
AB	6034051-002	Coupler, 21/11 tooth
AA	6034051-003	Coupler, 21/9 tooth
AD	6034051-004	Coupler, 21/15 tooth

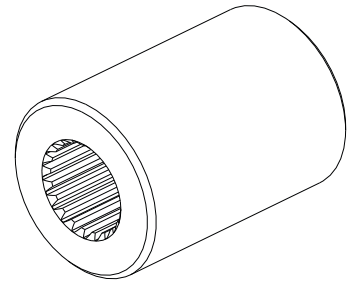
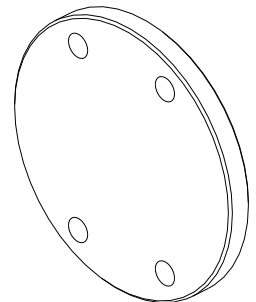

Table 14. Cover plate (Item 49)

Code position 26, 27	Part number	Description
AG	6034611-001	Cover plate



Hex head cap screw (cover plate) - Item 50

Cold start manifold (Destroke) - Item 53

Electronic displacement control S/A - Item 56

Table 15, 16 & 17

Table 15. Hex head cap screw (cover plate) (Item 50)

Code position 26, 27	Part number	Description
AG	473740	Hex head cap screw (cover plate)

Table 16. Cold start manifold (Destroke) (Item 53)

Code position 22, 23	Part number	Description
0C	631AA00288A-003	12 V DC Destroke manifold with integrated Deutsch connector
0K	631AA00288A-020	24 V DC destroke manifold with DIN connector

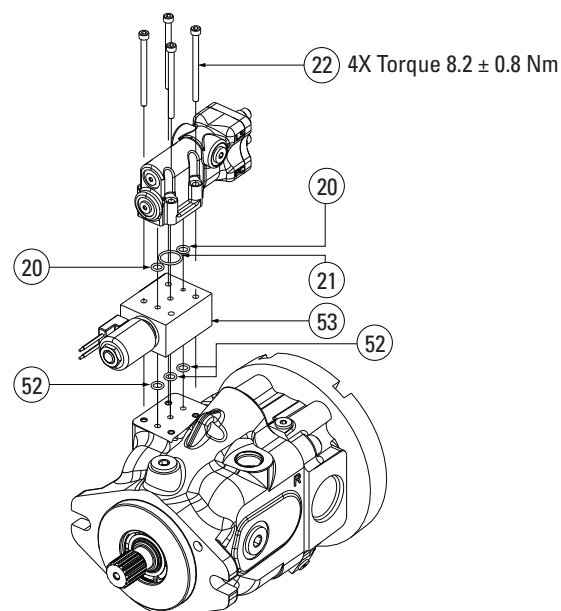
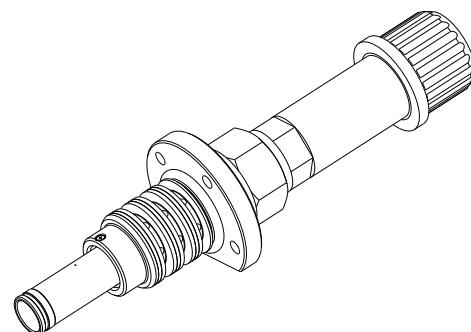

Table 17. Electronic displacement control S/A (Item 56)

Code position 14,15	Part number	Description
AT	6041219-003	EDC, EP type
AY	6041167-003	EDC, EPD type



220 Mobile piston pump repair

Cut section

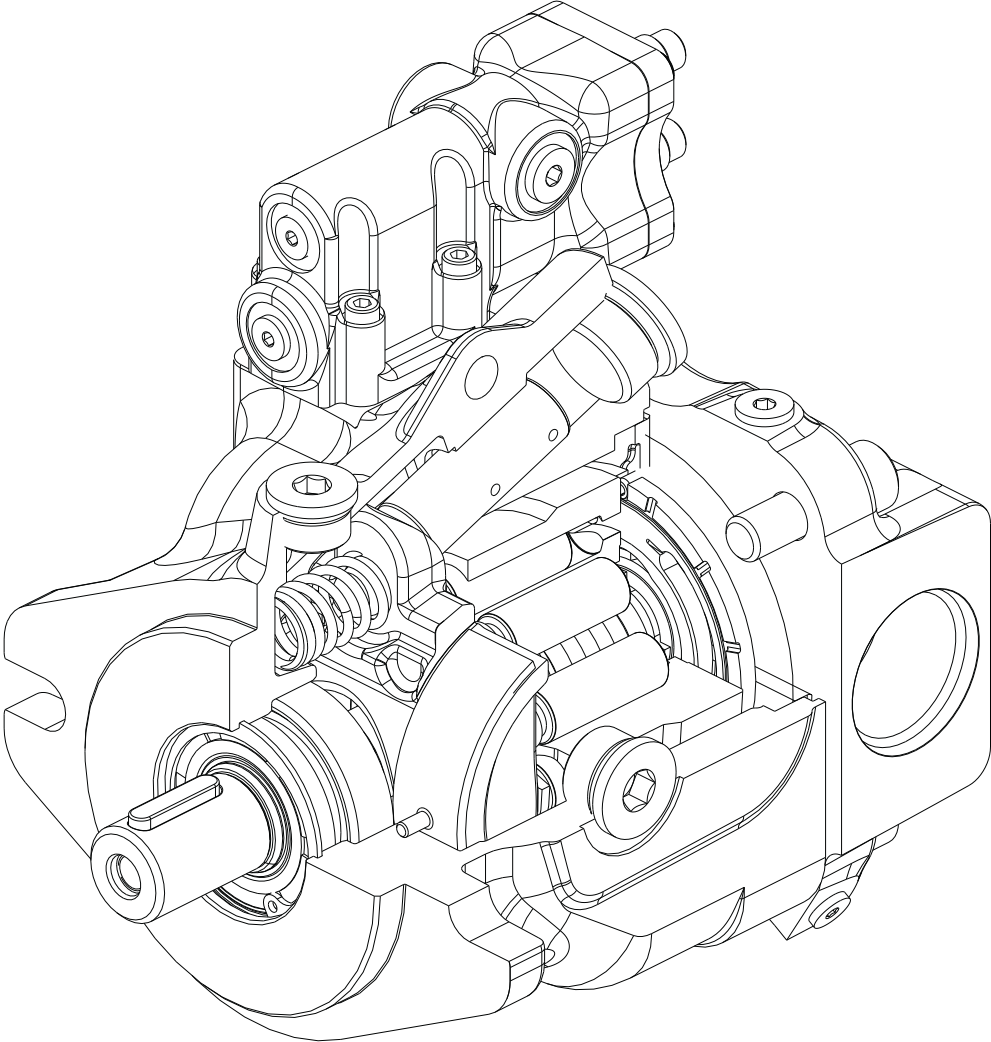

General information

Ordering replacement parts

Replacement parts

When ordering replacement parts, give the product number, date code, part name, part number and quantity of parts required. This product information is found stamped on the tag which is located on the side of the housing.

When the Eaton model 220 pressure, pressure-flow compensated piston pump is repaired, thoroughly clean the pump before any repairs are attempted.

The part number and serial number are on the tag.

Read this assembly manual thoroughly before starting work on the pumps.

This manual assumes appropriately trained technicians with specialized knowledge of mechanical and hydraulic component assembly and disassembly.

Serial Number/Date Code Interpretation

08 02 17 RC 1010

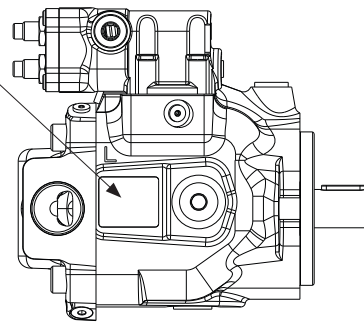
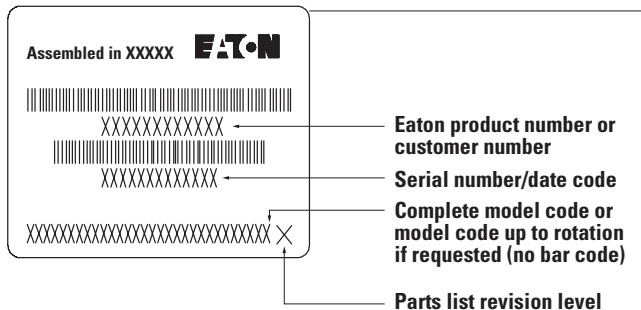
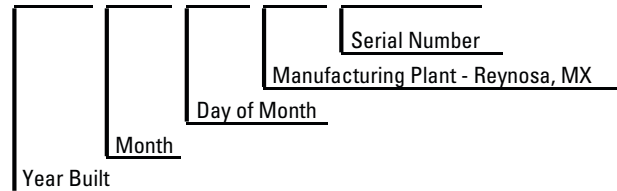

Required tools

Standard tools for disassembly

- Ball peen hammer
- Plastic tip hammer
- Flat tip screw driver
- Snap ring pliers
- Torque wrench
- Magnet stick
- 1-1/4" wrench
- 1-3/8" wrench
- 4 mm Allen wrench
- 3/32" Allen wrench
- Impact driver
- Slide hammer for bearing removal
- Dial indicator and accessories
- Marker or paint pen
- Petroleum jelly
- Cleaning solvent

Pump repair

Cut section

1. Remove control piston plug assembly



2. Install swash plate locator tool adjustment will take place in step 11.



3. Remove compensator



4. Remove end cover mark the housing and end cover to ensure orientation. Remove the four cap screws that hold the end cover in place.

Note: the valve plate may stick to end cover. Use caution so valve plate does not fall off.



5. Remove O-ring seal



6. Remove valve plate



7. Remove bearing race the bearing race is pressed in and will require the use of a sliding bearing removal hammer or similar tool to remove it.



8. Remove bearing



Pump repair

Cont.

9. Remove housing O-rings



11. Swashplate adjustment locator with the hold down tool in place, tighten the adjustment screw so the control piston spring is compressed.

Note: This step is designed to force the swashplate to a neutral position to enable easy removal of the rotating group, and to retain the swashplate.



13. Remove rotating group



15. Remove swashplate locator



10. Install Swashplate retainer install the swash plate hold down tool and tighten the cap screw. This will prevent the swash plate from moving.



12. Install shaft retainer tool and tighten the set screw while being careful not to damage shaft.



14. Remove shaft remove shaft retainer tool and lift out shaft. Use caution when moving shaft through shaft seal.



16. Remove swashplate retainer



Pump repair

Cont.

17. Remove control piston



18. Remove swashplate



19. Remove bias spring



20. Remove bearing



21. Remove cradle bearing screws caution: socket head cap screws are easily damaged during repair with improper tool.



22. Remove cradle bearings note: the cradle bearings are asymmetrical.
Note: proper orientation shown in picture.



23. Remove front bearing race



24. Remove shaft seal with the seal retaining ring removed use a punch or similar tool to knock out the shaft seal.



Inspection, repair and part replacement

Inspection

Inspection

Before inspection of parts, clean with a solvent that is compatible with system fluid.

Rotating group parts

1. Inspect cylinder block face for wear, scratches, and/or erosion. If cylinder block condition is questionable, replace the entire rotating group.
2. Remove the pistons, shoe retainer, and pivot from piston block. The piston block assembly doesn't need to be disassembled unless the internal pins or spring are damaged.
3. Check each cylinder block bore for excessive wear. Use the piston and shoe S/A for this purpose. The pistons should be a very close fit and slide in and out of the cylinder block bores. **NO BINDING CAN BE TOLERATED.** If binding occurs, clean the cylinder block and pistons. Lubricate the cylinder block bores with clean fluid and try again. Even minor contamination of the fluid may cause a piston to freeze up in a cylinder bore.
4. Inspect each of the nine piston and shoe S/A for a maximum end play of 0.005 inch between the piston and shoe. Also check the face dimension of each shoe. The face dimension must be within 0.001 inch.
5. Inspect shoe retainer and pivot for wear and/or scratches. If condition is questionable, replace entire rotating group.

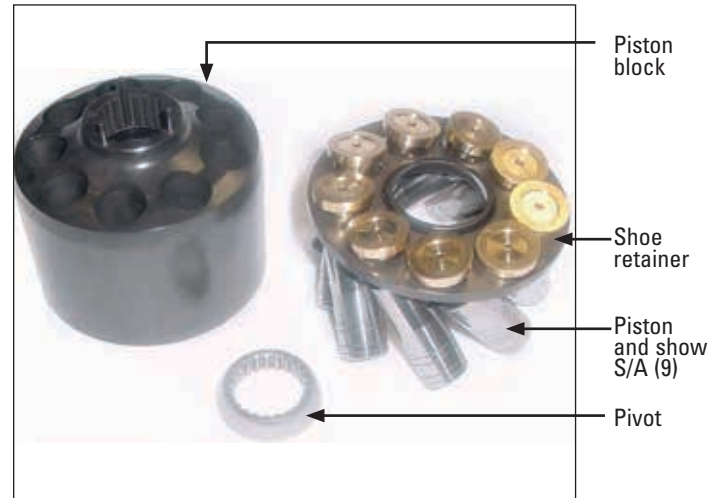

Note: Do not lap the face of piston block assembly.

Piston S/A tolerances

This dimension must be maintained on all nine shoes within 0.001 inch.

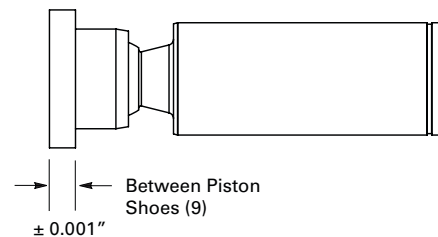

Shoe face rides on swash plate. Shoe must swivel smoothly on ball.
End play must not exceed 0.005 inch.

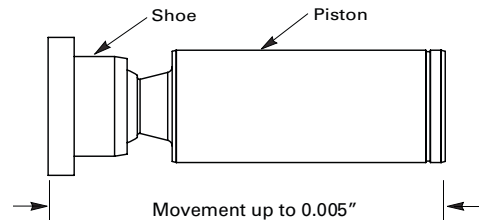

Inspection, repair and part replacement

End cover & associated parts

1. Inspect end cover for erosion, cracks, and burrs. Clean up minor burrs with an India stone. If erosion or cracks are found, replace the end cover.
2. Inspect roller bearing and bearing race for nicks and pitting. Make sure the roller bearing turns freely within the bearing race. If the roller bearing needs replacement, both the roller bearing and the bearing race must be replaced.
3. Inspect valve plate for erosion, excessive wear, heavy scratches, and cracks. If any of the above conditions are found, replace the valve plate.
4. Inspect control piston and maximum displacement screw for burrs, scratches and cracks. Clean up minor scratches with 500 grit paper. Remove burrs with an India stone. The control piston should move freely in the bore.

Swashplate parts

1. Inspect swashplate face for wear, roughness or scoring. Check the swashplate hubs and bearing surfaces for wear and cracks. Replace if defective.
2. Inspect saddle bearing surfaces for wear, pitting, and smooth operation. Replace if necessary.

Shaft/housing parts

1. Inspect drive shaft for wear, stripped splines, and burrs. Remove burrs with an India stone. Inspect the contact area of bearing and shaft seal). Replace the drive shaft if wear or scoring is greater than 0.005 T.I.R. (total indicator reading).
2. Inspect drive shaft bearing for roughness, pitting of rollers, and excessive end play. Replace, if defective. If the bearing needs to be replaced, the bearing race also requires replacement.
3. Inspect housing mounting flange for nicks and burrs. Remove minor nicks and burrs with an India stone. Also check the housing for damaged or stripped threads. If any thread is damaged, replace the housing.
4. Check remaining pump parts for excessive wear, damaged threads, burrs, cracks and erosion. Replace any part that is in questionable condition.

Inspection, Repair and Part Replacement

Shimming process

Shafty bearing shim kit 9900961-000

Shimming Process Installation Information

This shim kit is to replace the bearing spacer within the pump housing. If the housing, drive shaft, shaft bearings or end cover is replaced during servicing, the original bearing spacer can no longer be used to assure proper bearing set.

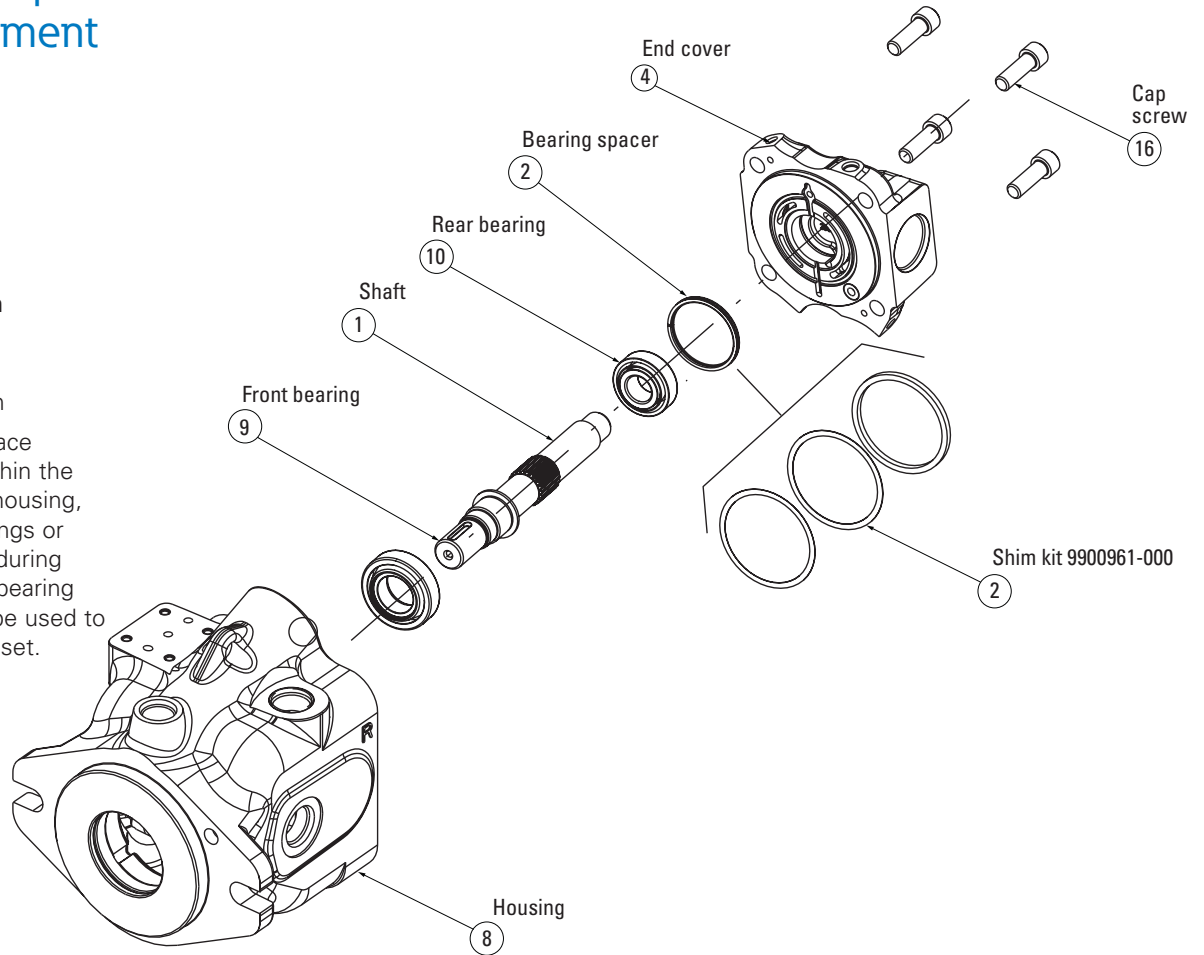

Shimming procedures

1. Measure the thickness of the existing bearing spacer.
2. To obtain a starting point, stack shims to a few thousandth of an inch less than the measurement of existing bearing spacer. Then insert shims into the end cover in the same location as the removed bearing spacer.
3. Assemble the housing (without interface O-ring seals), shaft bearings, shaft and end cover. Install the end cover cap screws and torque to 114 ± 11 Nm.
4. Using a dial indicator, measure drive shaft end play. Target shaft end play range is $.0005''$ to $.003''$ ($.013$ to $.08$ mm). Add or remove shims to achieve proper shaft end play. If no movement of the shaft is observed, shims will need to be removed and steps 3 and 4 repeated.
5. Finish the assembly of the pump.



1. Install snap ring and shaft seal



2. Insert the shaft bearing race



3. Install cradle bearings



Note: The cradle bearings are asymmetrical. Install as shown in picture.

4. Install cradle bearing screws



Note: The old cap screws cannot be reused and must be replaced with new ones because the screws will be damaged during disassembly. The new cap screw threads will be coated with loctite. (2) bearings item 11 and (2) screws item 12.

5. Install bearing



6. Install bias spring



7. Install swashplate



Note: With the bias spring in place, tilt the swash plate toward the spring and install the swash plate.

8. Install control piston



9. Install swashplate retainer



10. Install swashplate locator



Note: Adjust the screw until the swashplate is near neutral (will look flat in housing).

11. Install shaft



Caution: Use care while inserting shaft end through shaft seal.

12. Install shaft retainer tool



13. Install the rotating group



14. Remove swashplate locator



15. Remove swashplate retainer



16. Install O-ring seal



17. Install housing O-rings



18. Install bearing race into end cover



19. Install valve plate



Locating pin

Note: Lightly coat the back plate side of the valve plate with petroleum jelly for retention during assembly. Install the valve plate over the bearing race aligning the small slot on the outside of the valve plate with the roll pin in the end cover.

20. Install bearing onto shaft



21. Install end cover



Note: Ensure correct orientation. Use caution so valve plate does not fall off.

22. Install compensator



23. Testing

Perform functional test on pump according to Eaton test procedure. Contact your area sales manager for more information.

Assembly torque values

Instructions

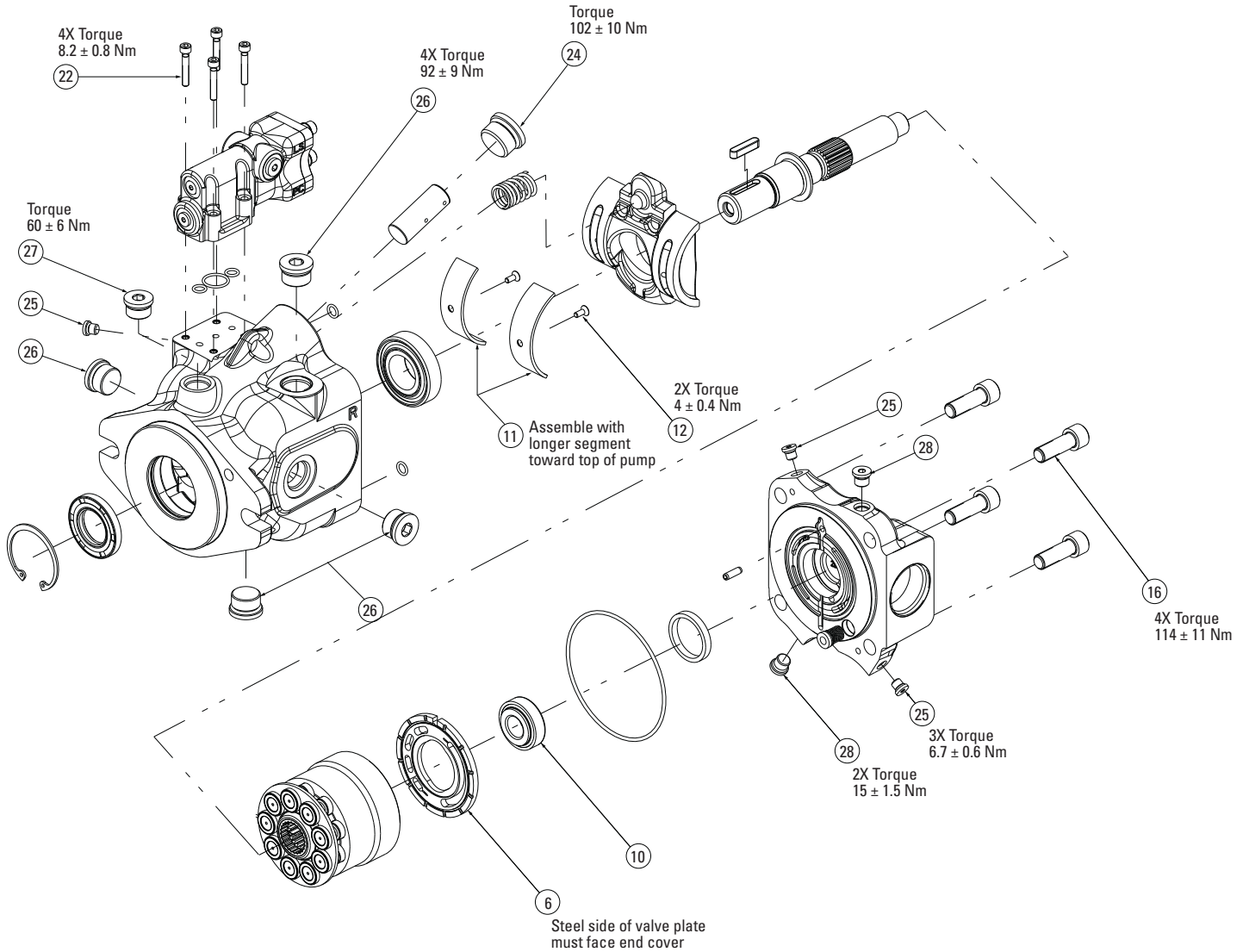

Feedback sensor option

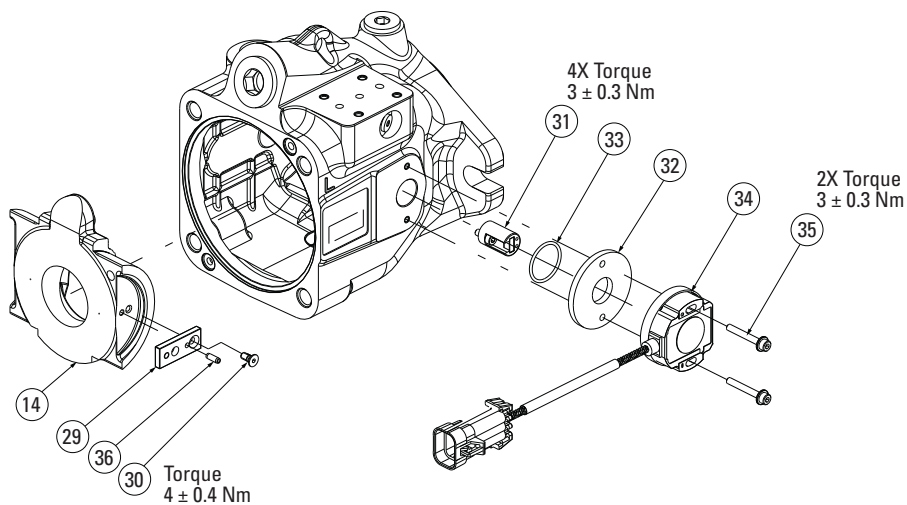

Assembly torque values

Instructions

Adjustable maximum stop option

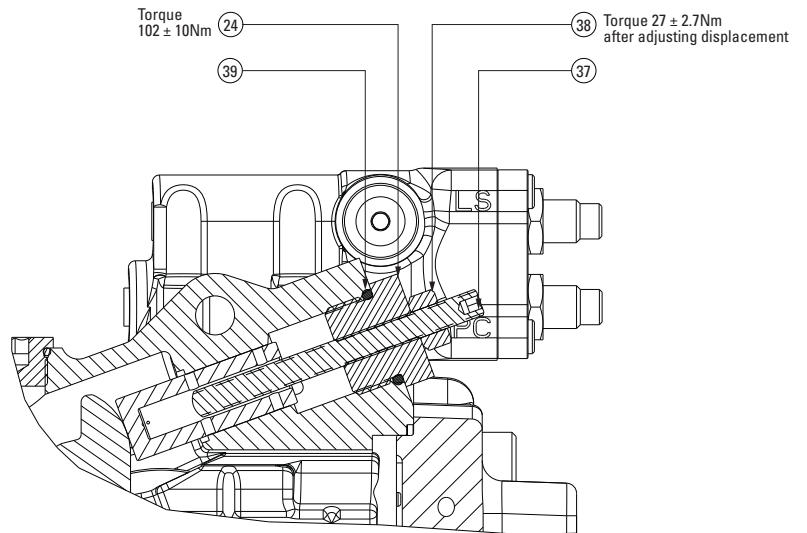

Cold start manifold (Destroke)

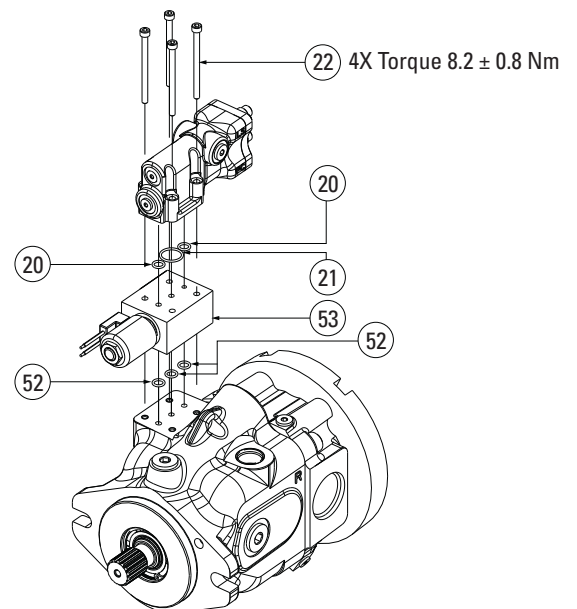

Eaton
Hydraulics Group USA
14615 Lone Oak Road
Eden Prairie, MN 55344
USA
Tel: 952-937-9800
Fax: 952-294-7722
www.eaton.com/hydraulics

Eaton
Hydraulics Group Europe
Route de la Longeraie 7
1110 Morges
Switzerland
Tel: +41 (0) 21 811 4600
Fax: +41 (0) 21 811 4601

Eaton
Hydraulics Group Asia Pacific
Eaton Building
No.7 Lane 280 Linhong Road
Changning District, Shanghai
200335 China
Tel: (+86 21) 5200 0099
Fax: (+86 21) 2230 7240